

100. /

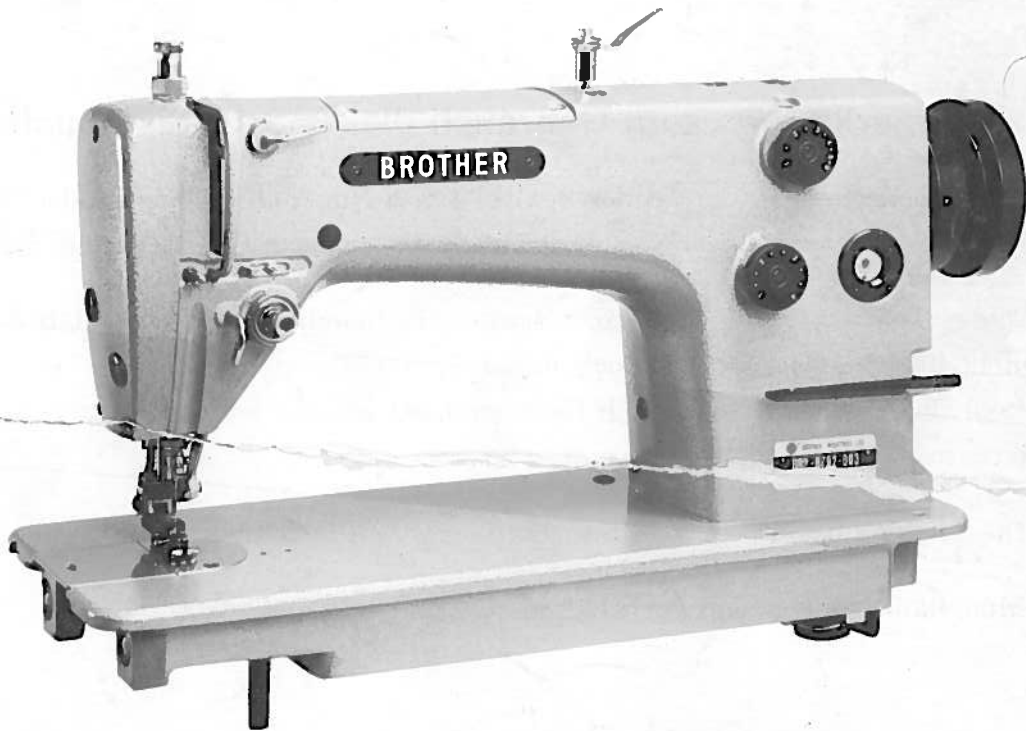

PARTS BOOK
FOR
BROTHER DB2-B792





Single Needle Adjustable Top and Bottom
Feed Lock Stitch Machine (with Thread Trimmer)

BROTHER INDUSTRIES, LTD.
NAGOYA, JAPAN



Notes for using this parts book

1. If the symbol  is found in the "Parts No." column or the "Assembly No." column, refer to the different parts list on page 23.
2. The symbol  in the "Parts No." column indicates that the parts is not available for supply. If, however, there is a number in the "Assembly No." column, the parts can be ordered as an assembly. Please, therefore, order by using the Assembly No..
3. This book was prepared based on information available in December, 1978.
4. Parts are subject to changes in design without prior notice.

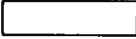

Anmerkungen zum Gebrauch dieses Stücklistebuches

1. Dieses Zeichen  in der Spalte "Parts No. (Teilnummer)" oder "Assembly No. (Gerätesatznummer)" verweist auf die Gesonderte Stückliste auf Seite 23.
2. Dieses Zeichen  in der Spalte "Teilnummer" bedeutet, daß dieser Teil nicht lieferbar ist. Wenn jedoch in der Spalte "Gerätesatznummer" eine Nummer steht, kann dieser Teil als ein Geräteteilsatz bestellt werden. Bestellen Sie daher bitte mit dieser Gerätesatznummer.
3. Dieses Buch basiert auf den Informationen vom Dezember, 1978.
4. Modelländerungen sind vorbehalten.

Notes sur l'utilisation de ce manuel de pièces détachées

1. Si le symbole  se trouve dans la colonne "Parts No. (N° de pièce)" ou dans la colonne "Assembly No. (N° jeu de pces)", veuillez vous référer à la liste de pièces annexe page 23.
2. Le symbole  dans la colonne "N° de pièce" signifie que la pièce ne peut être fournie. Si, dans la colonne "N° jeu de pces", il y a un numéro de nomenclature, la pièce peut être commandée comme faisant partie d'un jeu de pièces. Donc, pour toute commande, veuillez spécifier le n° du jeu de pièces.
3. Ce manuel a été fait d'après les renseignements valables au mois de Décembre, 1978.
4. Les pièces peuvent être sujettes à des modifications sans préavis.

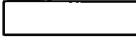
Notas para usar este Libro de Piezas

1. De haber un símbolo  junto al "Parts No. (Número de Pieza)" o en la columna del "Assembly No. (Número de Juego)", habrá que mirar la lista de piezas separada de la página 23.
2. El símbolo , que se encuentra en la columna del "Número de Pieza", quiere decir que no se dispone de dicha pieza sola. Cuando, empero, hay un número en la columna del "Numero de Juego", se podrá ordenar la pieza con todo el juego. Por lo tanto, será mejor hacer el pedido recurriendo al número del juego respectivo.
3. Este libro ha sido compilado basándose en los datos de que se disponía en Diciembre de 1978.
4. Las piezas quedan sujetas a cambios de diseño sin aviso previo.

CONTENTS

A. Machine Body and Threading	1
B. Needle Bar, Thread Take-up and Rotary Hook Mechanism	2
C. Feed Mechanism (Part 1).....	3
C. Feed Mechanism (Part 2).....	4
D. Upper Feed Mechanism (Part 1)	5
D. Upper Feed Mechanism (Part 2)	6
D. Upper Feed Mechanism (Part 3)	7
E. Presser Foot and Knee Lifter Mechanism	8
F. Lubrication (Part 1).....	9
F. Lubrication (Part 2).....	10
G. Quick Back Mechanism (-500·-600).....	11
H. Thread Trimmer and Tension Releaser (-500·-600).....	12
J. Thread Wiper (-500) and Quick Back Switch Mechanism (-500·-600).....	13
K. Synchronizer (-500·-600).....	14
Q. Valve Box (-500·-600)	15
R. Presser Lifter and Treadle Mechanism.....	16
S. Control Box.....	17
T. Motor (Part 1).....	18
T. Motor (Part 2).....	19
Z. Accessories.....	20
Gauge parts	21
DIFFERENT PARTS LIST	23
INDEX.....	27

A. Machine Body and Threading

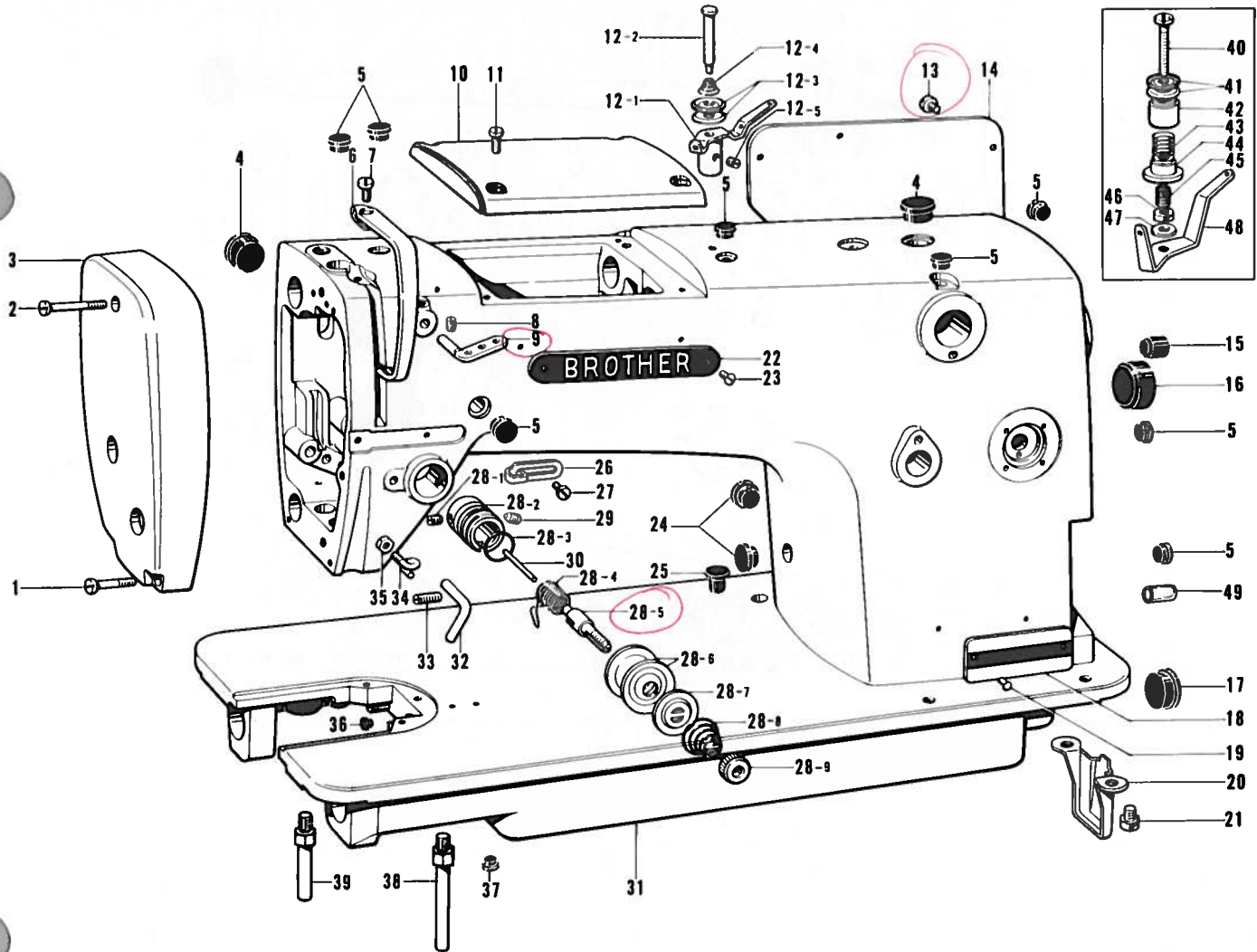

Ref. No.	Name of Parts	Q'ty	Parts No.	Assembly No.	Ref. No.	Name of Parts	Q'ty	Parts No.	Assembly No.
A-1	Screw	2	120311-0-02		A-28-1	Screw	1	100402-0-04	
A-2	Screw	1	151431-0-01		A-28-2	Upper Tension Regulator Bracket	1	144741-0-01	A-28 Upper Tension Regulator Assembly 181634-0-01
A-3	Face Plate	1			A-28-3	Packing	1	114294-0-01	
A-4	Oil Cap	2	104449-0-01		A-28-4	Thread Take-up Spring	1	145519-0-01	
A-5	Oil Cap	8	104450-0-01		A-28-5	Tension Stud	1	100398-0-01	
A-6	Thread Take-up Cover	1	140885-0-02		A-28-6	Tension Disc	2	145446-0-01	
A-7	Screw	1	009680-7-13		A-28-7	Tension Disc Washer	1	100134-0-01	
A-8	Screw	1	151602-0-02		A-28-8	Tension Spring	1	145520-0-01	
A-9	Thread Retainer	1	114931-0-01		A-28-9	Nut	1	100136-0-01	
A-10	Top Cover	1	151258-0-01		A-29	Screw	1	103950-0-02	
A-11	Screw	4	009681-0-14		A-30	Tension Release Pin	1	150551-0-00	
A-12-1	Pretension	1		A-12 Pretension Assembly	A-31	Arm Bed	1		
A-12-2	Pretension Stud	1			A-32	Thread Guide	1	116112-0-01	
A-12-3	Thread Guide Disc	2	144504-0-01		A-33	Screw	1	011711-4-12	
A-12-4	Spring	1	144505-0-00		A-34	Arm Thread Guide Left	1	145524-0-01	
A-12-5	Screw	1	102716-0-03		A-35	Nut	1	021660-1-02	
A-13	Screw	8	009670-8-12		A-36	Oil Cap	1		
A-14	Rear Cover	1			A-37	Oil Cap	1		
A-15	Oil Cap	1	104832-0-01		A-38	Bed Leg L	1	104829-1-01	
A-16	Oil Cap	1	104451-0-01		A-39	Bed Leg S	1	104830-1-01	
A-17	Oil Cap	1	108520-0-01		A-40	Pretension Stud	1		
A-18	Model Plate	1			A-41	Thread Guide Disc	2		
A-19	Model Plate Pin	2			A-42	Washer	1		
A-20	Pump Cover	1	118672-0-01		A-43	Spring	1		
A-21	Bolt	2	140704-0-01		A-44	Nut	1		
A-22	Name Plate BROTHER	1			A-45	Spring	1		
A-23	Screw	2			A-46	Nut	1		
A-24	Oil Cap	2	104821-0-01		A-47	Washer	1		
A-25	Oil Cap	1			A-48	Thread Guide Plate	1		
A-26	Arm Thread Guide Right	1	145522-0-01		A-49	Viny Tube	1	153132-0-00	
A-27	Screw	1	009670-6-14						

B. Needle Bar, Thread Take-up and Rotary Hook Mechanism

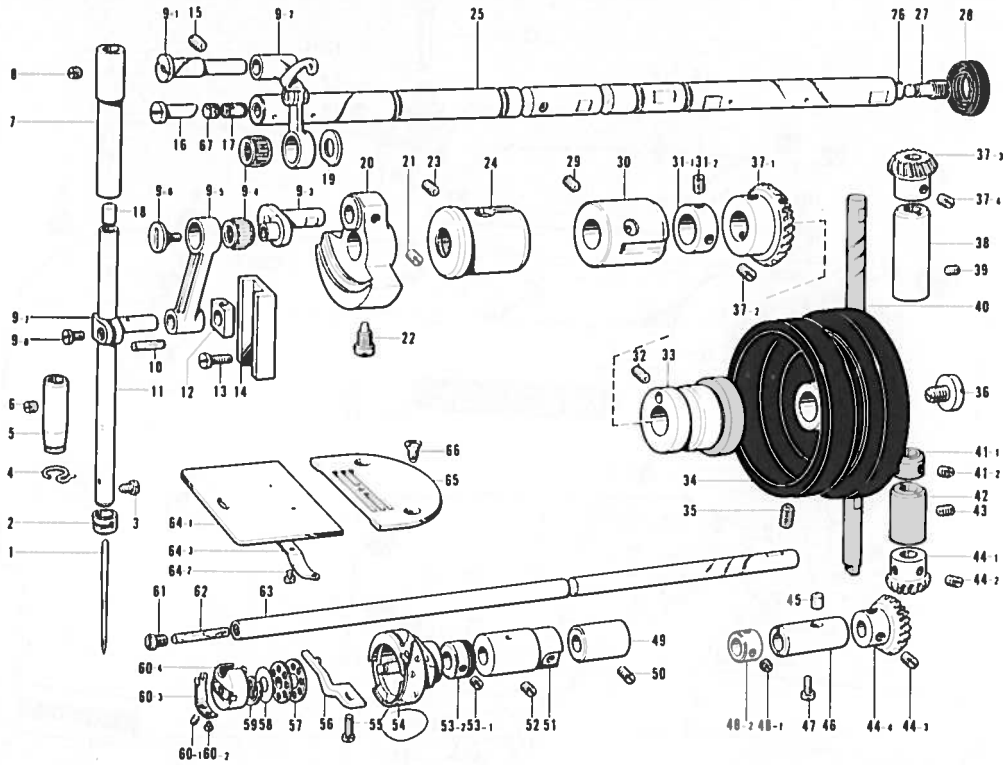

Ref. No.	Name of Parts	Q'ty	Parts No.	Assembly No.	Ref. No.	Name of Parts	Q'ty	Parts No.	Assembly No.
B-1	Needle DB×1	1	100263-0-31						
B-2	Needle Bar Thread Guide	1	145944-0-01		B-37-3	Vertical Shaft Upper Gear	1		B-37 Upper Gear Assembly 140378-0-01
B-3	Screw	1	140553-0-01		B-37-4	Screw	2	151606-0-01	
B-4	Thread Guide Under	1	100573-0-01		B-38	Vertical Shaft Upper Bushing	1	142708-0-00	
B-5	Needle Bar Bushing Lower	1	117243-0-01		B-39	Screw	1	013760-6-10	
B-6	Screw	1	100260-0-01		B-40	Vertical Shaft	1	145516-0-01	
B-7	Needle Bar Bushing Upper	1	117242-0-01		B-41-1	Set Collar	1		B-41 Collar with Screw 118759-0-01
B-8	Screw	1	100260-0-01		B-41-2	Screw	2	101706-0-03	
B-9-1	Stud	1			B-42	Vertical Shaft Lower Bushing	1	142709-0-00	
B-9-2	Thread Take-up Lever	1		B-9 Thread Take up Lever Assembly 147551-0-01	B-43	Screw	1	013761-4-10	
B-9-3	Needle Bar Crank	1			B-44-1	Vertical Shaft Lower Gear	1		B-44 Lower Gear Assembly 140381-0-01
B-9-4	Needle Roller Bearing	2	147777-0-00		B-44-2	Screw	2	151606-0-01	
B-9-5	Needle Bar Crank Rod	1			B-44-3	Screw	2	151606-0-01	
B-9-6	Screw	1	145465-0-01		B-44-4	Lower Shaft Gear	1		
B-9-7	Needle Bar Clamp	1			B-45	Felt	1	107155-0-01	
B-9-8	Screw	1	140004-0-01		B-46	Lower Shaft Bushing Right	1	104520-0-00	
B-10	Wick	1	108809-0-01		B-47	Screw	1	121007-0-01	
B-11	Needle Bar	1			B-48-1	Screw	2	101706-0-03	B-48 Collar with Screw 181995-0-01
B-12	Needle Bar Guide Slide Block	1	102630-0-01		B-48-2	Set Collar	1		
B-13	Screw	2	009670-6-12		B-49	Lower Shaft Bushing Middle	1	118762-0-00	
B-14	Needle Bar Guide	1	145688-0-00		B-50	Screw	1	151607-0-01	
B-15	Screw	1	151605-0-02		B-51	Lower Shaft Bushing Left	1	118761-0-00	
B-16	Oil Adjustor	1	146333-0-01		B-52	Screw	1	151603-0-02	
B-17	Felt	1	146327-0-01		B-53-1	Screw	2	151601-0-02	B-53 Oil Stopper Assembly
B-18	Needle Bar Cork	1	111863-0-01		B-53-2	Oil Stopper	1		
B-19	Washer	1	110367-0-01		B-54	Rotary Hook Assembly	1		
B-20	Thread Take-up Crank	1	148965-0-00		B-55	Screw	1	107407-0-03	
B-21	Screw	2	151606-0-01		B-56	Bobbin Case Holder Position Bracket	1	100367-0-01	
B-22	Screw	1	104464-0-01		B-57	Bobbin	1		
B-23	Screw	1	151604-0-01		B-58	Bobbin Case Sheet	1		
B-24	Upper Shaft Bushing Left	1	145459-1-01		B-59	Bobbin Presser Spring	1		
B-25	Upper Shaft	1	151260-0-01		B-60-1	Spring Adjusting Screw	1	181937-0-01	B-60 Bobbin Case Assembly
B-26	O Ring	1	081002-6-70		B-60-2	Spring Set Screw	1	181938-0-01	
B-27	Oil Screw Right	1	104555-0-01		B-60-3	Lower Thread Adjusting Spring	1	182392-0-01	
B-28	Oil Seal	1	101487-0-00		B-60-4	Bobbin Case	1		
B-29	Screw	1	151604-0-01		B-61	Screw	1	109173-0-01	
B-30	Upper Shaft Bushing Middle	1	140726-0-00		B-62	Felt	1	145751-0-01	
B-31-1	Set Collar	1		B-31 Collar with Screw 181916-0-01	B-63	Lower Shaft	1	145517-0-01	
B-31-2	Screw	2	151606-0-01		B-64-1	Slide Plate	1		B-64 Slide Plate Assembly 180018-0-01
B-32	Screw	1	013760-6-10		B-64-2	Screw	2	122771-0-01	
B-33	Upper Shaft Bushing Right	1	145461-1-01		B-64-3	Slide Plate Spring	1	114561-0-01	
B-34	Pulley	1			B-65	Needle Plate	1		
B-35	Screw	2	013761-4-10		B-66	Screw	2	151267-0-01	
B-36	Screw	1			B-67	Felt	1	107149-0-01	
B-37-1	Upper Shaft Gear	1		B-37 Upper Gear Assembly 140378-0-01					
B-37-2	Screw	2	151606-0-01						

C. Feed Mechanism (Part 1)

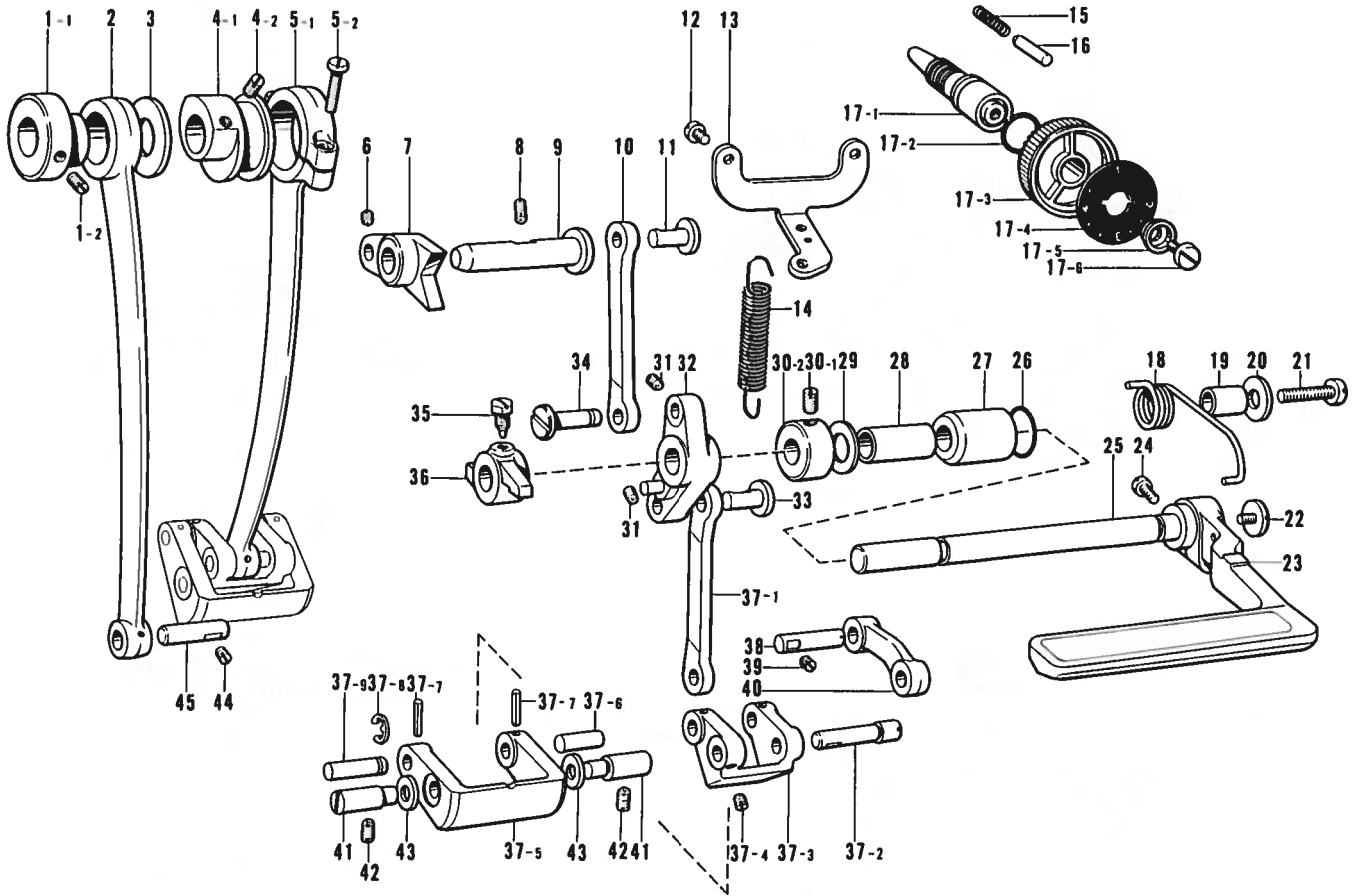

Ref. No.	Name of Parts	Q'ty	Parts No.	Assembly No.	Ref. No.	Name of Parts	Q'ty	Parts No.	Assembly No.
C-1-1	Vertical Feed Eccentric Wheel	1		C-1 Vertical Feed Assembly 180791-0-01	C-23	Reverse Lever	1		
C-1-2	Screw	2	151604-0-01		C-24	Screw	1		
C-2	Vertical Feed Connecting Rod	1	118758-0-01		C-25	Reverse Lever Shaft	1		
C-3	Stopper	1	101482-0-01		C-26	O Ring	1	104564-0-01	
C-4-1	Eccentric Wheel	1		C-4 Eccentric Wheel Assembly 180792-0-01	C-27	Reverse Lever Shaft Bushing	1	151314-0-00	
C-4-2	Screw	2	151604-0-01		C-28	Collar	1	118748-0-01	
C-5-1	Crank Rod	1		C-5 Crank Rod Assembly 151301-0-01	C-29	Washer	1	025100-1-30	
C-5-2	Screw	2	144712-0-01		C-30-1	Screw	2	151604-0-01	C-30 Collar with Screw 118824-0-01
C-6	Screw	1	151601-0-02		C-30-2	Set Collar	1		
C-7	Feed Regulator	1	151311-0-01		C-31	Screw	2	151601-0-02	
C-8	Screw	1	151604-0-01		C-32	Feed Regulator Lever Lower Assembly	1	151306-0-01	
C-9	Feed Regulator Shaft	1	145492-0-01		C-33	Connecting Lever Stud	1	151308-0-01	
C-10	Reverse Feed Connecting Lever	1	151304-0-01		C-34	Connecting Lever Stud	1	151309-0-01	
C-11	Connecting Lever Stud	1	151308-0-01		C-35	Bolt	1	108749-0-01	
C-12	Spring Hook	1	151332-0-01		C-36	Feed Regulator Lever	1	151310-0-01	
C-13	Screw	2	009670-6-12		C-37-1	Reverse Feed Connecting Lever	1	151304-0-01	
C-14	Spring	1			C-37-2	Link Stud	1	118737-0-01	
C-15	Spring	1	100328-0-01		C-37-3	Level Feed Link	1	118729-0-01	C-37 Feed Regulator Assembly 151303-0-01
C-16	Pin	1	145502-0-01		C-37-4	Screw	1	151601-0-02	
C-17-1	Length Control Screw	1	109151-1-01	C-17 Length Control Assembly 151443-0-01	C-37-5	Feed Regulator	1		
C-17-2	Packing	1	108549-0-01		C-37-6	Level Feed Link Stud Small	1	118732-0-01	
C-17-3	Length Control Dial	1	151320-0-01		C-37-7	Pin	2	118733-0-01	
C-17-4	Feed Regulator Plate	1	151321-0-01		C-37-8	Stop Ring	1	048040-3-42	
C-17-5	Washer	1	142746-0-02		C-37-9	Level Feed Link Stud Large	1	151305-0-01	
C-17-6	Screw	1	142747-0-02		C-38	Feed Rock Shaft Arm Pin	1	118740-0-01	
C-18	Spring	1			C-39	Screw	1	151601-0-02	
C-19	Collar	1		C-40	Level Feed Connecting Rod	1	118736-0-01		
C-20	Washer	1		C-41	Feed Regulator Shaft	2	118734-0-01		
C-21	Screw	1		C-42	Screw	2	151604-0-01		
C-22	Screw	1	100511-0-03	C-43	Washer	2	118735-0-01		
					C-44	Screw	1	151601-0-02	
					C-45	Feed Rock Shaft Arm Pin	1	109153-0-01	

C. Feed Mechanism (Part 2)

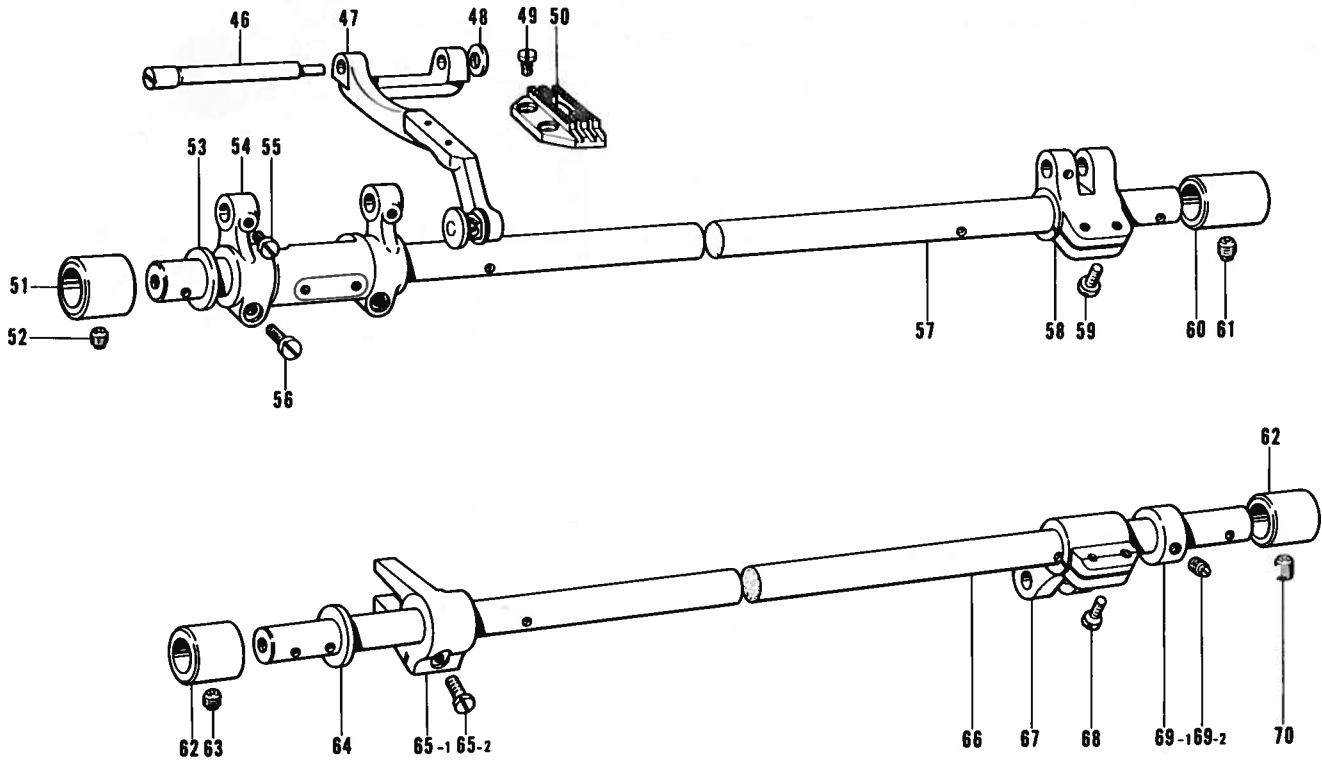

Ref. No.	Name of Parts	Q'ty	Parts No.	Assembly No.	Ref. No.	Name of Parts	Q'ty	Parts No.	Assembly No.
C-46	Feed Bar Shaft	1	116917-0-01		C-62	Feed Shaft Bushing Small	2	116766-0-01	
C-47	Feed Bar Assembly	1	151322-0-01		C-63	Screw	1	101706-0-01	
C-48	Thrust Ring	1	115663-0-01		C-64	Thrust Ring	1	116920-0-01	
C-49	Screw	2	100080-0-03		C-65-1	Feed Lifting Arm	1		C-65 Feed Lifting Arm Assembly 151444-0-01
C-50	Feed Dog	1			C-65-2	Screw	1	009681-6-12	
C-51	Feed Shaft Bushing Small	1	116766-0-01		C-66	Feed Lifting Rock Shaft	1	151330-0-01	
C-52	Screw	1	101706-0-01		C-67	Feed Lifting Rock Shaft Arm	1	116768-0-01	
C-53	Thrust Ring	1	116920-0-01		C-68	Screw	2	009681-2-12	
C-54	Feed Bar Arm	1	145510-0-00		C-69-1	Set Collar	1		C-69 Collar with Screw 180321-0-01
C-55	Screw	2	104908-0-01		C-69-2	Screw	2	101706-0-01	
C-56	Screw	2	009681-2-12		C-70	Screw	1	151606-0-01	
C-57	Feed Rock Shaft	1	142573-0-01						
C-58	Feed Rock Shaft Arm	1	148286-0-01						
C-59	Screw	2	009711-2-12						
C-60	Feed Shaft Bushing Left	1	116919-0-01						
C-61	Screw	1	101706-0-01						

D. Upper Feed Mechanism (Part 1)

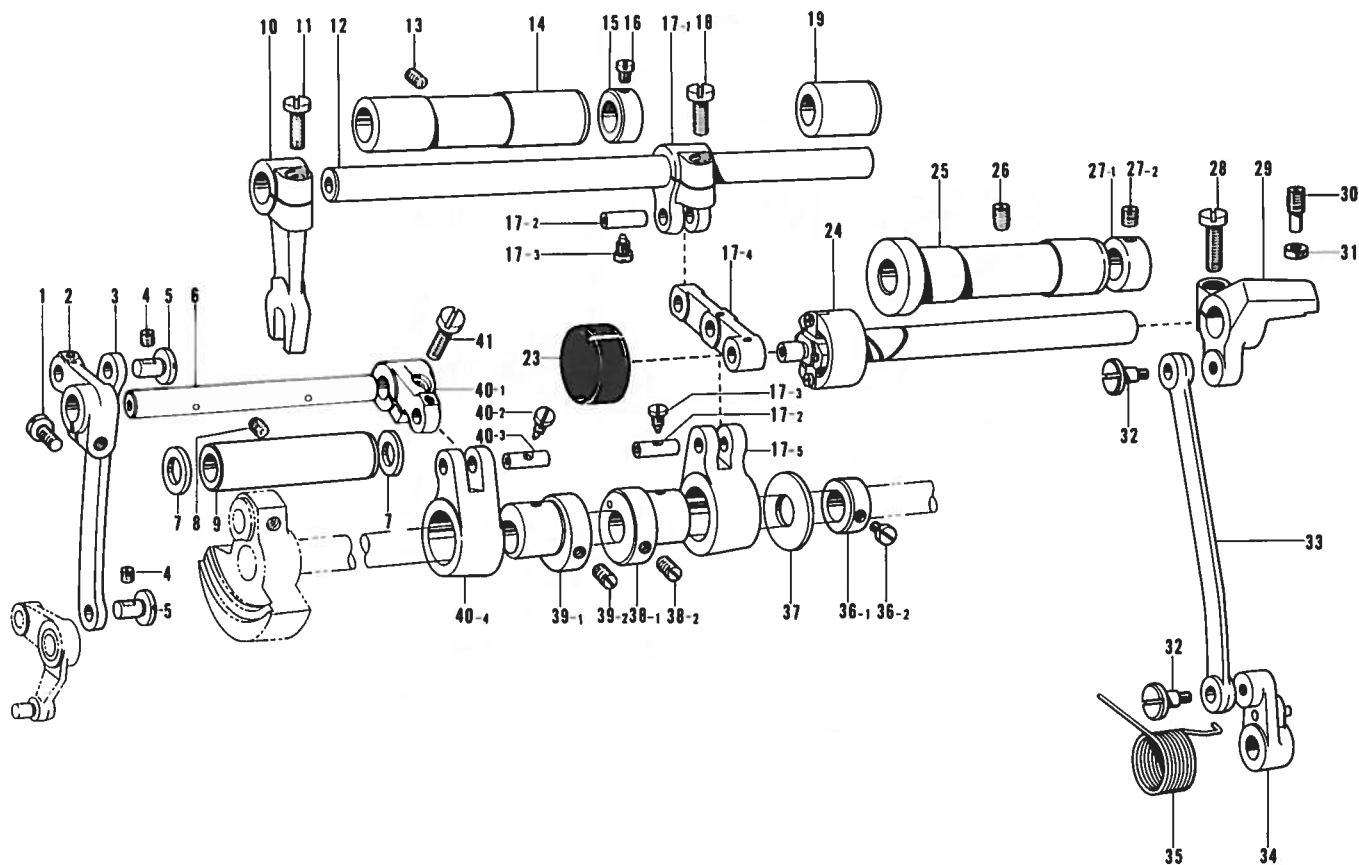

Ref. No.	Name of Parts	Q'ty	Parts No.	Assembly No.	Ref. No.	Name of Parts	Q'ty	Parts No.	Assembly No.
D-1	Screw	1	009751-6-12		D-27-1	Set Collar	1		D-27 Collar with Screw 180321-0-01
D-2	Upper Feed Lifting Rock Lever	1	151397-0-01		D-27-2	Screw	2	151606-0-01	
D-3	Upper Feed Lifting Rock Connector	1	151395-0-01		D-28	Screw	1	009781-8-12	
D-4	Screw	2	151601-0-02		D-29	Upper Feed Regulator	1		
D-5	Connecting Stud	2	151396-0-01		D-30	Screw	1		
D-6	Upper Feed Lifting Rock Shaft	1	151398-0-01		D-31	Nut	1	100022-0-05	
D-7	Crank Ring	2	142628-0-01		D-32	Screw	2	120263-0-02	
D-8	Screw	1	151604-0-01		D-33	Upper Feed Regulator Connecting Bar	1	151351-0-01	
D-9	Upper Feed Lifting Rock Shaft Bushing	1	151399-0-00		D-34	Feed Regulator Lever Upper Assembly	1	151348-0-01	
D-10	Upper Feed Rock Arm Upper	1	151369-0-01		D-35	Spring	1	151350-0-01	
D-11	Screw	1	009751-6-12		D-36-1	Set Collar	1		D-36 Collar with Screw 180321-0-01
D-12	Upper Feed Rock Shaft	1	151366-0-01		D-36-2	Screw	2	151606-0-01	
D-13	Screw	1	151604-0-01		D-37	Stopper Plate	1	101482-0-01	
D-14	Upper Feed Rock Shaft Bushing Left	1	151368-0-00		D-38-1	Upper Feed Eccentric Wheel	1		D-38 Upper Feed Eccentric Wheel Assembly 183005-0-01
D-15	Set Collar	1	140092-0-01		D-38-2	Screw	2	151604-0-01	
D-16	Screw	2	100366-0-01		D-39-1	Eccentric Wheel	1		D-39 Eccentric Wheel Assembly 183006-0-01
D-17-1	Upper Feed Rock Arm	1	151363-0-01	D-17 Upper Feed Rock Connecting Lever Assembly 151360-0-01	D-39-2	Screw	2	151604-0-01	
D-17-2	Stud	2	110562-0-01		D-40-1	Upper Feed Lifting Rock Shaft Arm	1	151401-0-01	D-40 Upper Feed Lifting Rock Connecting Lever Assembly 151400-0-01
D-17-3	Screw	2	153060-0-01		D-40-2	Screw	1	110563-0-01	
D-17-4	Horizontal Feed Connector	1	151362-0-01		D-40-3	Arm Pin	1	110562-0-01	
D-17-5	Upper Feed Rock Connecting Lever	1	151361-0-01	D-40-4	Upper Feed Lifting Rock Connecting Lever	1	151361-0-01		
D-18	Screw	1	009751-6-12		D-41	Screw	1	009751-6-12	
D-19	Upper Feed Rock Shaft Bushing Right	1	151367-0-00						
D-23	Oil Cap	1	151424-0-01						
D-24	Feed Regulator Shaft Assembly	1	151354-0-01						
D-25	Feed Regulator Shaft Bushing	1	151359-0-01						
D-26	Screw	1	151604-0-01						

D. Upper Feed Mechanism (Part 2)

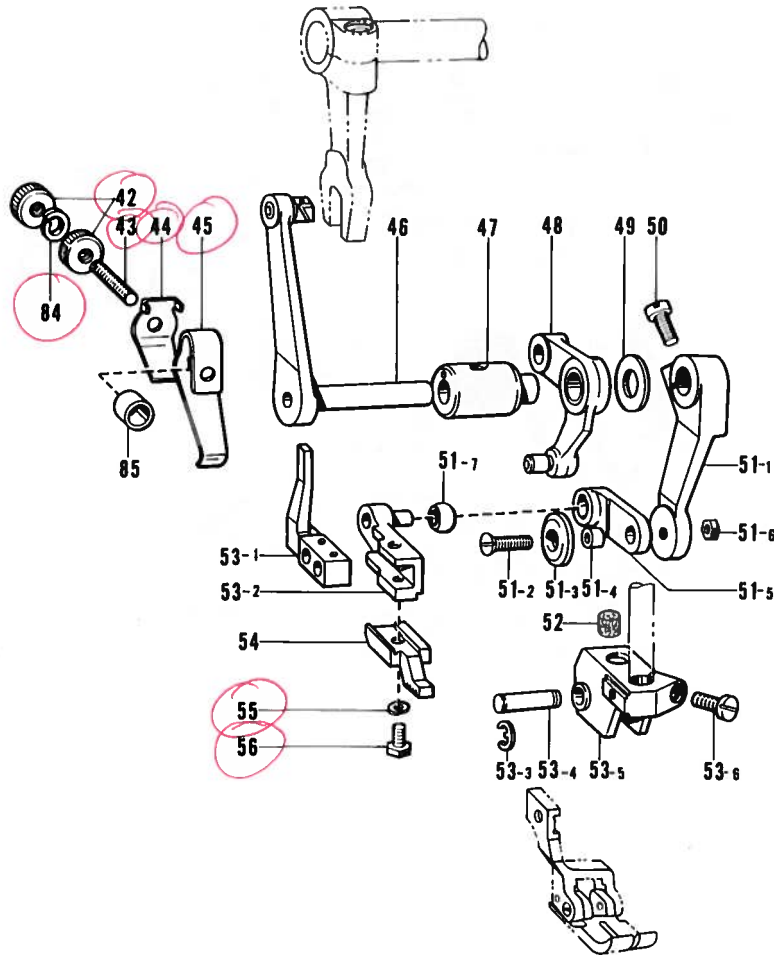

Ref. No.	Name of Parts	Q'ty	Parts No.	Assembly No.	Ref. No.	Name of Parts	Q'ty	Parts No.	Assembly No.
D-42	Nut	2	107682-0-01		D-51-5	Upper Feed Link	1	151375-0-00	D-51 Upper Feed Arm Assembly 151373-0-01
D-43	Screw	1	151392-0-01		D-51-6	Nut	1	021670-1-02	
D-44	Upper Feed Plate Spring Upper	1	151390-0-01		D-51-7	Round Bushing	1	153110-0-01	
D-45	Upper Feed Plate Spring Lower	1	151391-0-01		D-52	Felt	1	107155-0-01	
D-46	Upper Feed Rock Arm Lower Assembly	1	151370-0-01		D-53-1	Upper Feed Crank	1		D-53 Upper Feed Dog Setting Bracket 151377-0-01
D-47	Upper Feed Rock Arm Lower Bushing	1	151372-0-01		D-53-2	Upper Feed Dog Setting Bracket	1		
D-48	Upper Feed Lifting Rock Crank Assembly	1	151393-0-01		D-53-3	Stop Ring	2	048030-3-42	
D-49	Washer	1	153113-0-01		D-53-4	Stud	1	151382-0-01	
D-50	Screw	1	009681-0-12		D-53-5	Upper Feed B	1		
D-51-1	Upper Feed Arm	1		D-51 Upper Feed Arm Assembly 151373-0-01	D-53-6	Screw	1	009681-0-12	
D-51-2	Screw	1	151626-0-01		D-54	Upper Feed Dog	1		
D-51-3	Thrust Ring	1	151364-0-01		D-55	Spring Washer	1	028350-2-42	
D-51-4	Collar	1	151376-0-01		D-56	Bolt	1	144075-0-01	
					D-84	Spring Washer	1	028680-2-43	
					D-85	Collar	1	146288-0-01	

D. Upper Feed Mechanism (Part 3)

For stretching

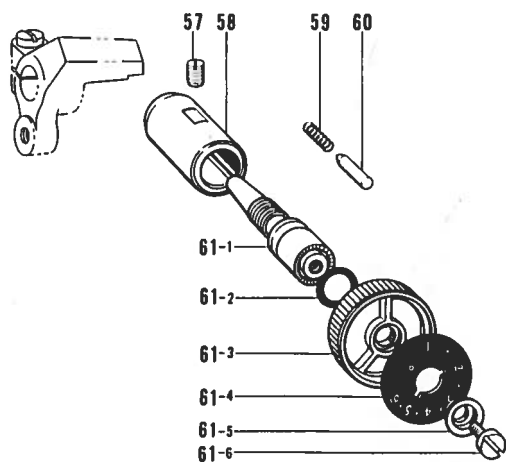

For shirring

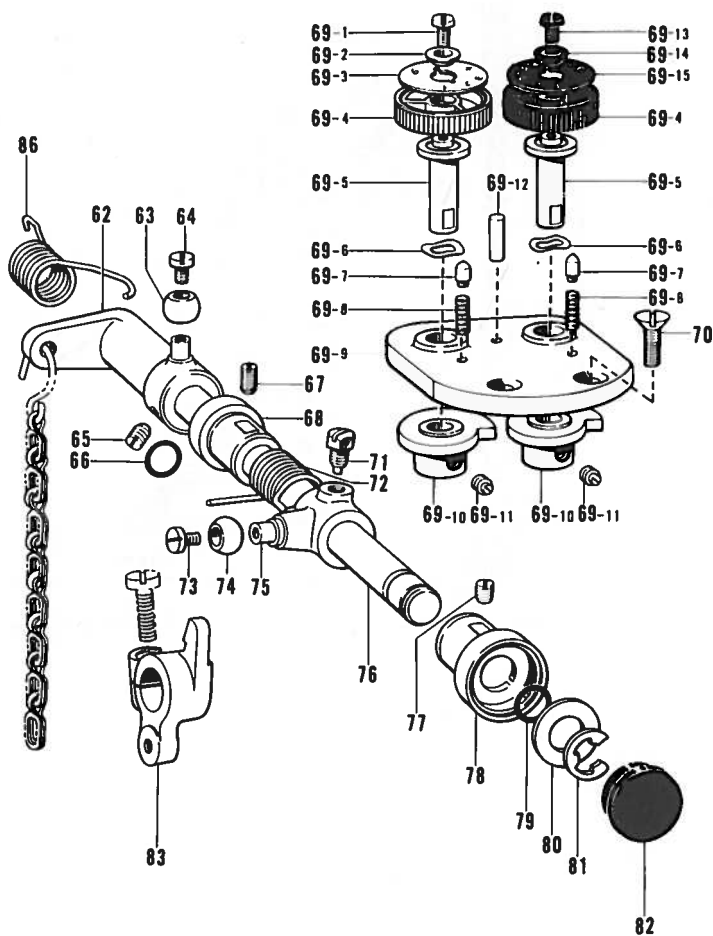

Ref. No.	Name of Parts	Q'ty	Parts No.	Assembly No.	Ref. No.	Name of Parts	Q'ty	Parts No.	Assembly No.
D-57	Screw	1	013760-6-10		D-69- 7	Pin	2	120305-0-01	
D-58	Upper Feed Regulator Bushing	1	151347-0-00		D-69- 8	Spring	2	113956-0-01	
D-59	Spring	1	144876-0-01		D-69- 9	Upper Feed Regulator Bracket	1	151413-0-01	D-69 Upper Feed Regulator Bracket Assembly 151412-0-01
D-60	Pin	1	145502-0-01		D-69-10	Upper Feed Regulator Cam	2	151415-0-01	
D-61-1	Length Control Screw	1	109151-1-01	D-61 Length Control Assembly 151445-0-01	D-69-11	Screw	4	100058-0-01	
D-61-2	Packing	1	108549-0-01		D-69-12	Pin	1	105095-0-01	
D-61-3	Length Control Dial	1	151320-0-01		D-69-13	Screw	1	142747-0-02	
D-61-4	Feed Regulator Plate	1	151346-0-01		D-69-14	Washer	1	142746-0-02	
D-61-5	Washer	1	142746-0-02		D-69-15	Feed Regulator Plate Right	1	151416-0-01	
D-61-6	Screw	1	142747-0-02		D-70	Screw	2	003761-2-12	
D-62	Shirring Lever	1		D-62 - 64 Shirring Lever Assembly 151450-0-01	D-71	Bolt	1	108749-0-01	
D-63	Round Bushing	1	141331-0-01		D-72	Spring	1	151409-0-01	
D-64	Screw	1	009680-5-12		D-73	Screw	1	009680-5-12	D-73 - 75 Upper Feed Regulator Arm Assembly 151449-0-01
D-65	Screw	2	013760-6-12	D-74	Round Bushing	1	141331-0-01		
D-66	O Ring	1	109203-0-01		D-75	Upper Feed Regulator Arm	1		
D-67	Screw	1	151603-0-01		D-76	Upper Feed Regulator Shaft	1	151405-0-01	
D-68	Upper Feed Regulator Bushing Back	1	151407-0-01		D-77	Screw	1	013760-6-10	
D-69-1	Screw	1	142747-0-01	D-69 Upper Feed Regulator Bracket Assembly 151412-0-01	D-78	Upper Feed Regulator Bushing Front	1	151406-0-01	
D-69-2	Washer	1	142746-0-01		D-79	O Ring	1	110558-0-01	
D-69-3	Feed Regulator Plate Left	1	151417-0-01		D-80	Collar	1	120023-0-01	
D-69-4	Length Control Dial	2	151320-0-01		D-81	Stop Ring	1	048090-3-42	
D-69-5	Upper Feed Regulator Cam Shaft	2	151414-0-01		D-82	Oil Cap	1	151418-0-01	
D-69-6	Spring	2	100315-0-02		D-83	Upper Feed Regulator	1	151353-0-01	
					D-86	Spring	1	153169-0-01	

※Parts of D-57~61 are for -003, -503 Specifications.

※Parts of D-62~86 are for -013, -613 Specifications.

E. Presser Foot and Knee Lifter Mechanism

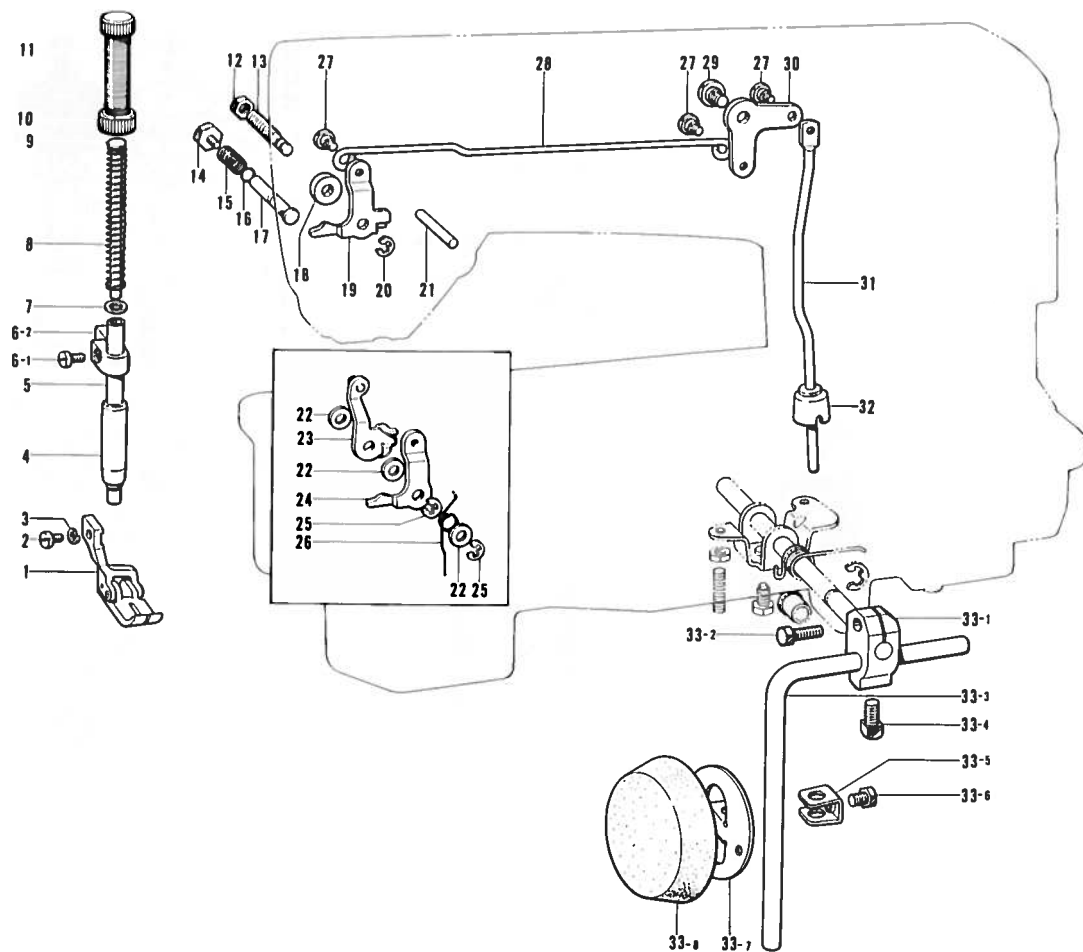

Ref. No.	Name of Parts	Q'ty	Parts No.	Assembly No.	Ref. No.	Name of Parts	Q'ty	Parts No.	Assembly No.
E-1	Presser Foot Assembly	1			E-20	Stop Ring	1		
E-2	Screw	1	009670-8-12		E-21	Tension Release Pin	1		
E-3	Washer	1	028350-2-42		E-22	Washer	3		
E-4	Presser Bar Bushing	1	145472-0-01		E-23	Tension Release Plate	1		
E-5	Presser Bar	1	151268-0-01		E-24	Presser Bar Lifter Lever	1		
E-6-1	Screw	1	009671-0-12	E-6 Presser Bar Bracket Assembly 180952-0-01	E-25	Stop Ring	2		
E-6-2	Presser Bar Bracket	1			E-26	Spring	1		
E-7	Washer	1	140407-0-01		E-27	Screw	3	145478-0-01	
E-8	Spring	1	141728-0-01		E-28	Knee Lifter Connector	1	145476-0-01	
E-9	Presser Spring Bar	1	141208-0-01		E-29	Screw	1	145480-0-01	
E-10	Nut	1	147846-0-01		E-30	Knee Lifter Lever	1	145479-0-01	
E-11	Screw	1	141207-0-01		E-31	Knee Lifter Bar	1	145481-0-01	
E-12	Nut	1	106147-0-01		E-32	Knee Lifter Complying Bar	1	145573-0-00	
E-13	Presser Bar Lifter Lever Stud	1	151269-0-01		E-33-1	Knee Lifter Joint	1	146039-0-01	
E-14	Bolt	1	151276-0-01		E-33-2	Bolt	1	017762-0-13	
E-15	Spring	1	151275-0-01		E-33-3	Knee Lifter Bar	1	104619-0-02	E-33 Knee Lifter Assembly
E-16	O Ring	1	081003-0-70		E-33-4	Bolt	1	100463-0-01	
E-17	Presser Bar Lifter Stud	1	151274-0-01		E-33-5	Knee Lifter Plate Stopper	1	114967-0-01	
E-18	Washer	1			E-33-6	Bolt	1	110087-0-01	
E-19	Presser Bar Lifter Lever	1			E-33-7	Knee Lifter Plate	1	114966-0-01	
					E-33-8	Knee Lifter Cover	1	140503-0-01	

F. Lubrication (Part 1)

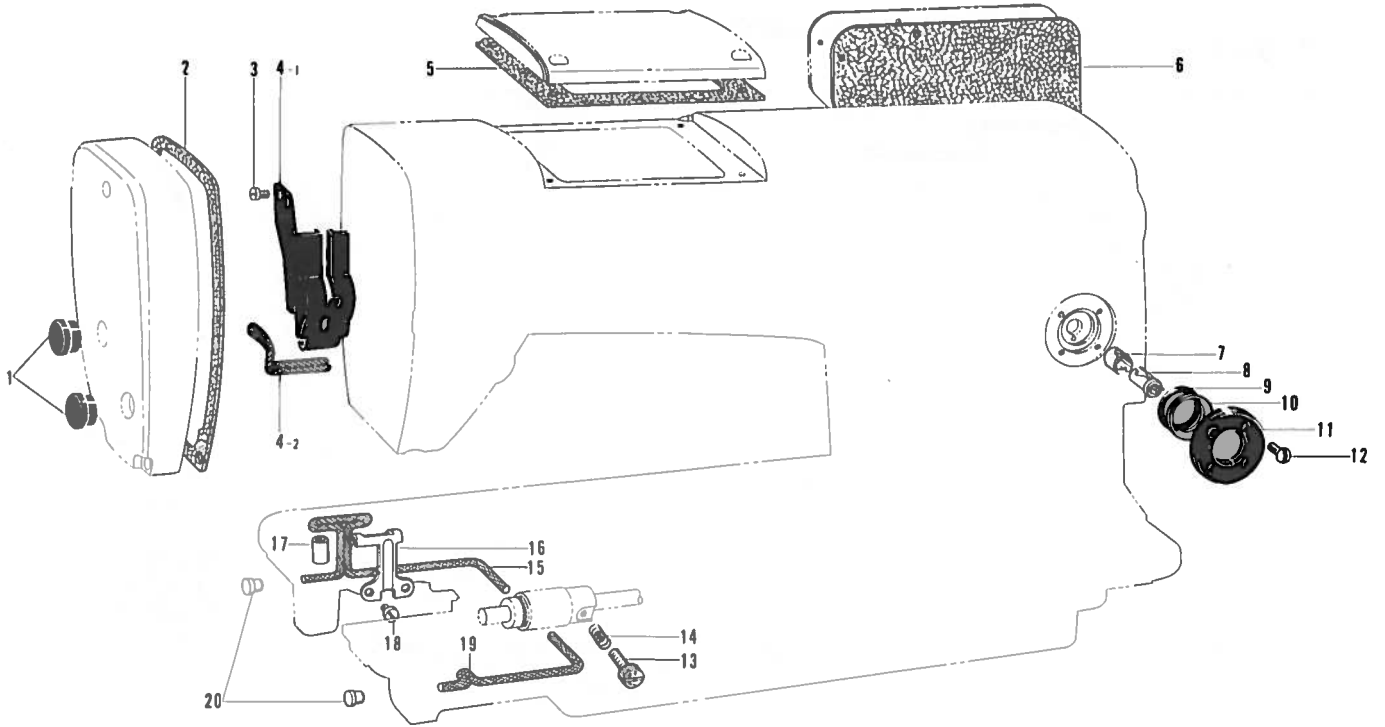

Ref. No.	Name of Parts	Q'ty	Parts No.	Assembly No.	Ref. No.	Name of Parts	Q'ty	Parts No.	Assembly No.
F-1	Oil Cap	2	101449-0-01		F-10	Oil Gauge Window	1	104547-0-01	
F-2	Packing	1	151419-0-00		F-11	Oil Gauge Flange	1	104546-0-01	
F-3	Screw	2	009670-5-12		F-12	Screw	4	102538-0-02	
F-4-1	Oil Stopper Plate	1		F-4	Oil Stopper Plate Assembly	1	145534-0-01		
F-4-2	Wick	1	109405-0-01	151448-0-01	F-13	Screw	1	145534-0-01	
F-5	Packing	1	151420-0-00		F-14	Spring	1	116794-0-01	
F-6	Packing	1			F-15	Wick	1	108801-0-01	
F-7	Tube Holder Cap	1	146314-0-00		F-16	Wick Supporter	1	109171-0-01	
F-8	Tube Holder	1	145529-0-00		F-17	Vinyl Tube	1	104566-0-01	
F-9	O Ring	1	081014-6-70		F-18	Screw	2	009679-3-12	
					F-19	Wick	1	108802-0-01	
					F-20	Oil Cap	6	111865-0-01	

F. Lubrication (Part 2)

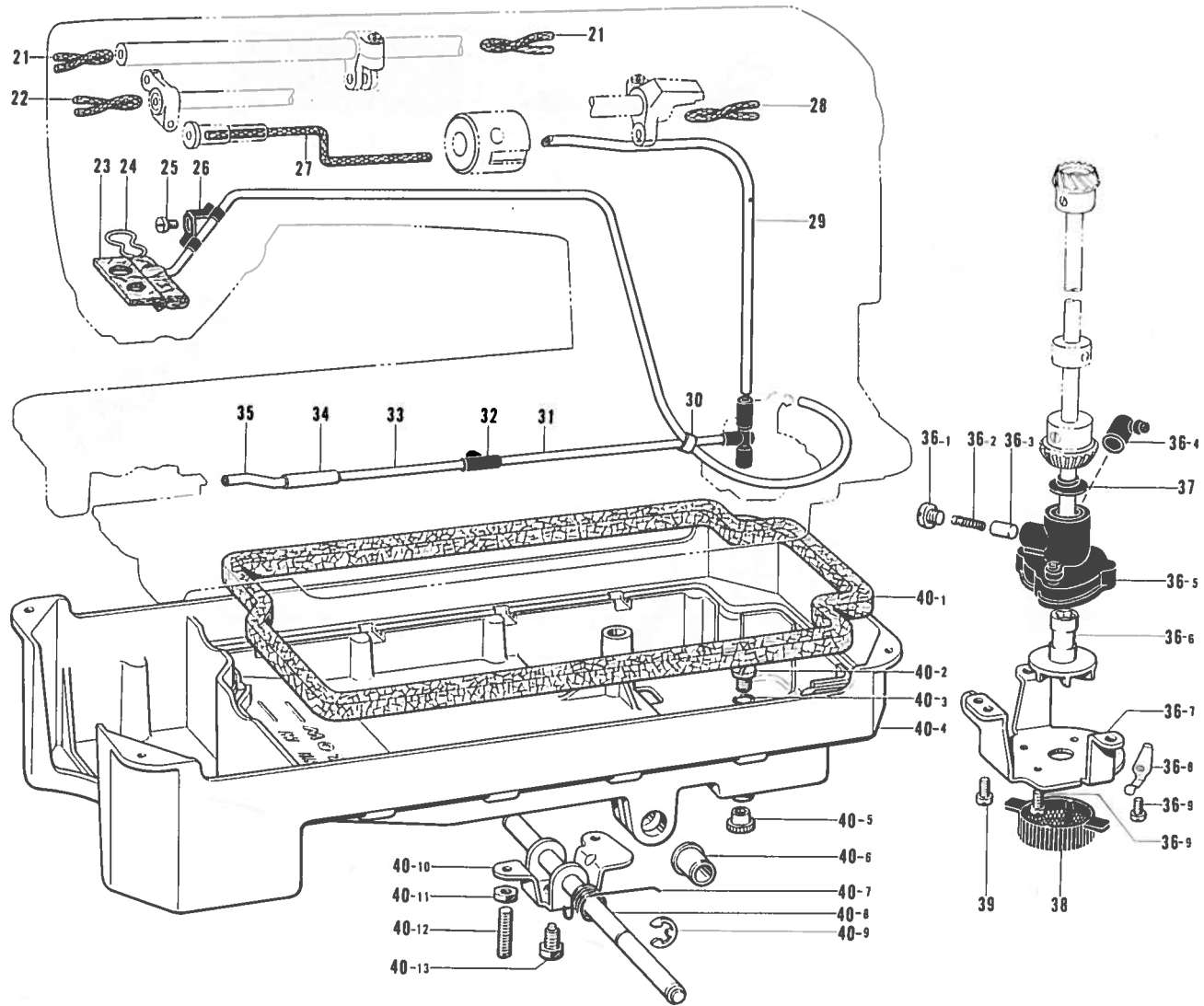

Ref. No.	Name of Parts	Q'ty	Parts No.	Assembly No.	Ref. No.	Name of Parts	Q'ty	Parts No.	Assembly No.
F-21	Wick	2	108802-0-01		F-36-6	Pump Propeller	1	148849-0-01	F-36
F-22	Wick	1	108801-0-01		F-36-7	Pump	1	144869-0-01	Pump
F-23	Tube Assembly	1	145543-0-01		F-36-8	Spring	2	144874-0-01	Assembly
F-24	Felt Supporter	1	145737-0-01		F-36-9	Screw	4	009670-8-12	181476-1-01
F-25	Screw	1	009670-5-13		F-37	Oil Stopper	1	146196-0-01	
F-26	Tube Holder	1	151429-0-01		F-38	Pump Filter	1	144872-0-01	
F-27	Wick	1	118768-0-01		F-39	Screw	3	009680-7-13	
F-28	Wick	1	108802-0-01		F-40-1	Packing	1	146040-0-01	
F-29	Upper Oil Tube	1	151425-0-00		F-40-2	Screw	1	140518-0-01	
F-30	Vinyl Tube	1	146253-0-00		F-40-3	O Ring	1	081007-0-70	
F-31	Lower Oil Tube	1	151426-0-01		F-40-4	Oil Pan	1		
F-32	Tube Joint	1	146324-0-01		F-40-5	Oil Cap	1	140480-0-01	
F-33	Oil Tube	1	151428-0-00		F-40-6	Bushing	2	149578-0-00	F-40
F-34	Tube Joint	1	149998-0-00		F-40-7	Spring			Oil Pan
F-35	Oil Tube	1	149999-0-00		F-40-8	Knee Lifter Shaft	1		Assembly
F-36-1	Screw	1	112467-0-02	F-36	F-40-9	Stop Ring	1	146293-0-01	
F-36-2	Spring	1	144876-0-01	Pump	F-40-10	Knee Lifter	1	146037-0-01	
F-36-3	Plunger	1	144875-0-01	Assembly	F-40-11	Nut	2	100022-0-04	
F-36-4	Joint	1	144878-0-01	181476-1-01	F-40-12	Screw	2	104885-0-01	
F-36-5	Pump Body	1	148848-0-01		F-40-13	Bolt	1	146367-0-01	

G. Quick Back Mechanism (-500-600)

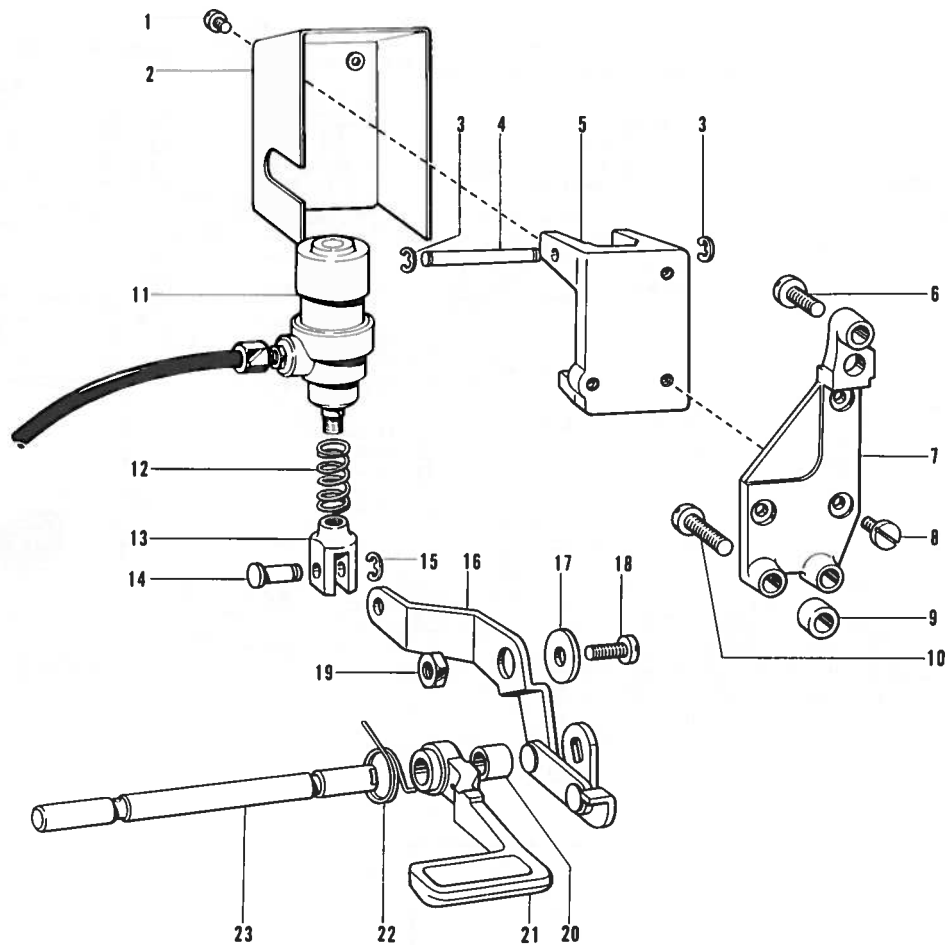

Ref. No.	Name of Parts	Q'ty	Parts No.	Assembly No.	Ref. No.	Name of Parts	Q'ty	Parts No.	Assembly No.
G-1	Screw	2	009670-5-13		G-13	Piston Rod Joint	1	140627-0-01	
G-2	Cylinder Cover	1	146156-0-01		G-14	Pin	1	146153-0-01	
G-3	Stop Ring	2	048040-3-42		G-15	Stop Ring	2	048040-3-42	
G-4	Cylinder Support Stud	1	146148-0-01		G-16	Reverse Link Lever Assembly	1	151343-0-01	
G-5	Cylinder Supporter	1	148853-0-01		G-17	Washer	1	149095-0-01	
G-6	Screw	1	009781-8-12		G-18	Screw	1	009761-4-12	
G-7	Reverse Solenoid Bracket	1	151333-0-01		G-19	Solenoid Lever Stud	1	149094-0-01	
G-8	Screw	3	007500-8-12		G-20	Collar	1		
G-9	Collar	2	151334-0-01		G-21	Reverse Lever	1		
G-10	Screw	2	009782-5-12		G-22	Spring	1		
G-11	Reverse Cylinder Assembly	1	146149-0-01		G-23	Reverse Lever Shaft	1		
G-12	Spring	1	151345-0-01						

H. Thread Trimmer and Tension Releaser (-500-600)

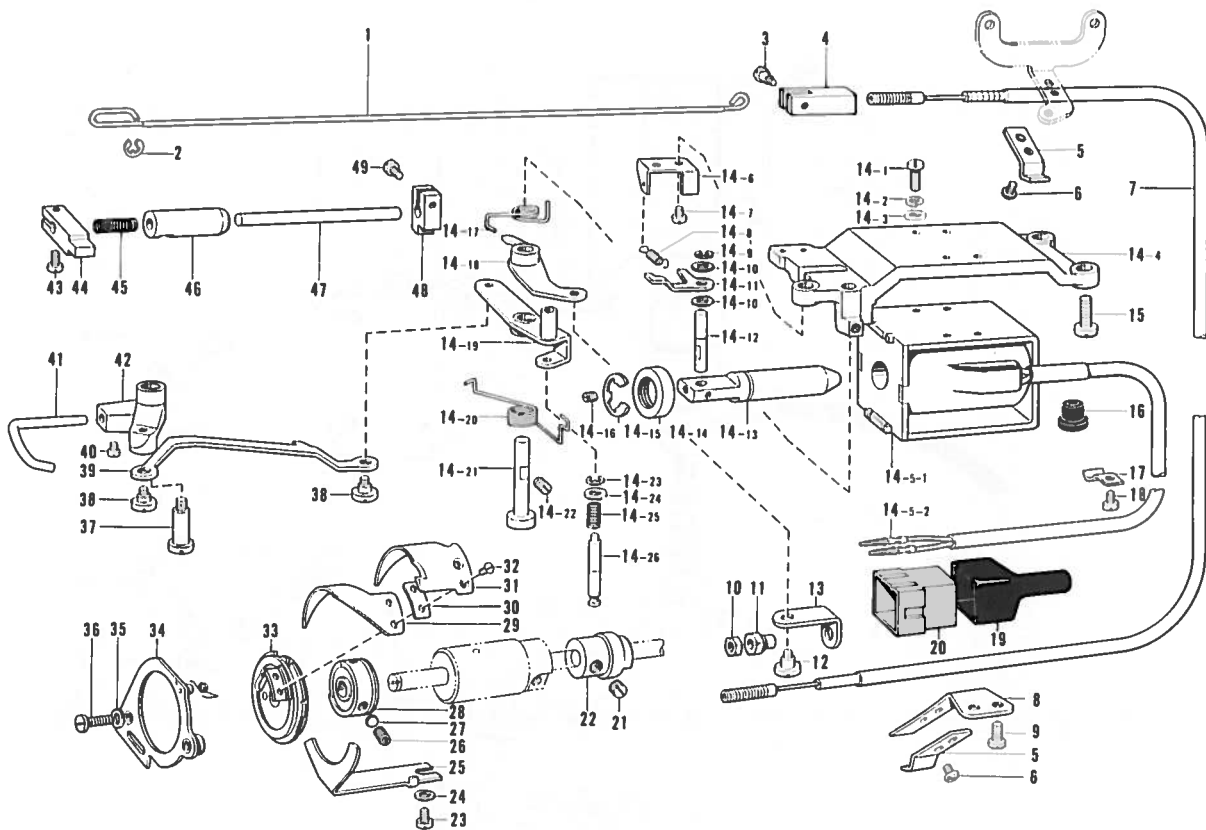

Ref. No.	Name of Parts	Q'ty	Parts No.	Assembly No.	Ref. No.	Name of Parts	Q'ty	Parts No.	Assembly No.
H- 1	Tension Release Bar	1	151432-0-01		H-14-24	Washer	1	025040-2-32	H-14 Thread Trimming Solenoid Bracket Assembly
H- 2	Stop Ring	1	048030-3-42		H-14-25	Spring	1	150352-0-00	
H- 3	Stud Screw	1	149137-0-01		H-14-26	Bobbin Finger Lever Shaft	1	149724-0-01	
H- 4	Tension Release Wire Joint	1	149136-0-01		H-15	Screw	3	009781-4-12	
H- 5	Tension Release Wire Presser	2	149133-1-01		H-16	Cord Bushing	1	146080-0-00	
H- 6	Screw	2	001670-6-12		H-17	Cord Holder	1	145595-0-01	
H- 7	Tension Release Wire	1	149130-1-01		H-18	Screw	1	009680-6-12	
H- 8	Tension Release Wire Holder	1	149132-0-01		H-19	Connector Cap	1		
H- 9	Screw	2	009680-6-12		H-20	Nylon Connector	1		
H-10	Nut	1	021670-2-03		H-21	Bobbin Finger Driving Cam	1	149725-0-01	
H-11	Wire Sleeve	1	149775-0-01		H-22	Screw	2	101706-0-01	
H-12	Stud Screw	1	149127-0-01		H-23	Screw	1	009680-7-13	
H-13	Tension Release Link	1	149131-0-01		H-24	Washer	1	025680-1-33	
H-14- 1	Screw	4	007401-0-12		H-25	Cover	1	149128-0-01	
H-14- 2	Spring Washer	4	028040-2-43		H-26	Screw	3	014680-6-22	
H-14- 3	Washer	4	025040-1-33		H-27	Washer	3	147697-0-01	
H-14- 4	Thread Trimming Solenoid Bracket	1			H-28	Thread Trimming Clutch	1	149709-0-01	
H-14- 5-1	Thread Trimming Solenoid	1		H-14-5 Thread Trimming Solenoid Assembly	H-29	Lower Thread Finger	1	145610-1-01	
H-14- 5-2	Cord Bushing	1			H-30	Spacer	1	145611-0-00	
H-14- 5-3	Terminal Pin	2			H-31	Movable Knife	1	145608-0-01	
H-14- 6	Thread Trimming Claw Stopper	1	149120-0-01		H-32	Screw	2	141542-0-01	
H-14- 7	Screw	2	100242-0-03		H-33	Movable Knife Holder	1	149710-0-01	
H-14- 8	Spring	1	149121-0-01		H-34	Movable Knife Holder Plate	1	149712-0-01	
H-14- 9	Stop Ring	1	048030-3-42		H-35	Washer	2	100645-0-03	
H-14-10	Washer	2	100645-0-03		H-36	Screw	2	009681-2-12	
H-14-11	Thread Trimming Claw	1	149114-0-01	H-14 Thread Trimming Solenoid Bracket Assembly	H-37	Bobbin Finger Crank Stud	1	149124-0-01	
H-14-12	Plunger Pin	1	149113-0-01		H-38	Stud Screw	2	149127-0-01	
H-14-13	Plunger	1			H-39	Bobbin Finger Connector	1	149726-0-01	
H-14-14	Stopper	1	149112-0-01		H-40	Screw	2	144458-0-01	
H-14-15	Stop Ring	1	048090-3-42		H-41	Bobbin Finger	1	149125-0-01	
H-14-16	Screw	1	013679-4-12		H-42	Bobbin Finger Crank	1	149123-0-01	
H-14-17	Spring	1	149115-0-01		H-43	Screw	1	009660-7-12	
H-14-18	Thread Trimming Lever	1	149722-0-01		H-44	Stopper	1	145617-0-01	
H-14-19	Bobbin Finger Lever	1	149723-0-01		H-45	Spring	1	145621-0-01	
H-14-20	Spring	1	149118-0-01		H-46	Thread Trimming Shaft Bushing	1	149105-0-00	
H-14-21	Thread Trimming Lever Shaft	1	149119-0-01		H-47	Thread Trimming Shaft	1	149104-0-01	
H-14-22	Screw	1	151602-0-02		H-48	Thread Trimming Claw Black	1	149106-0-01	
H-14-23	Stop Ring	1	048030-3-42		H-49	Screw	1	009660-7-12	

※Parts of H-1~H-13 are Tension Releaser (-500-600).

※Parts of H-14~H-49 are Thread Trimmer (-500-600).

J. Thread Wiper (-500) and Quick Back Switch Mechanism (-500-600)

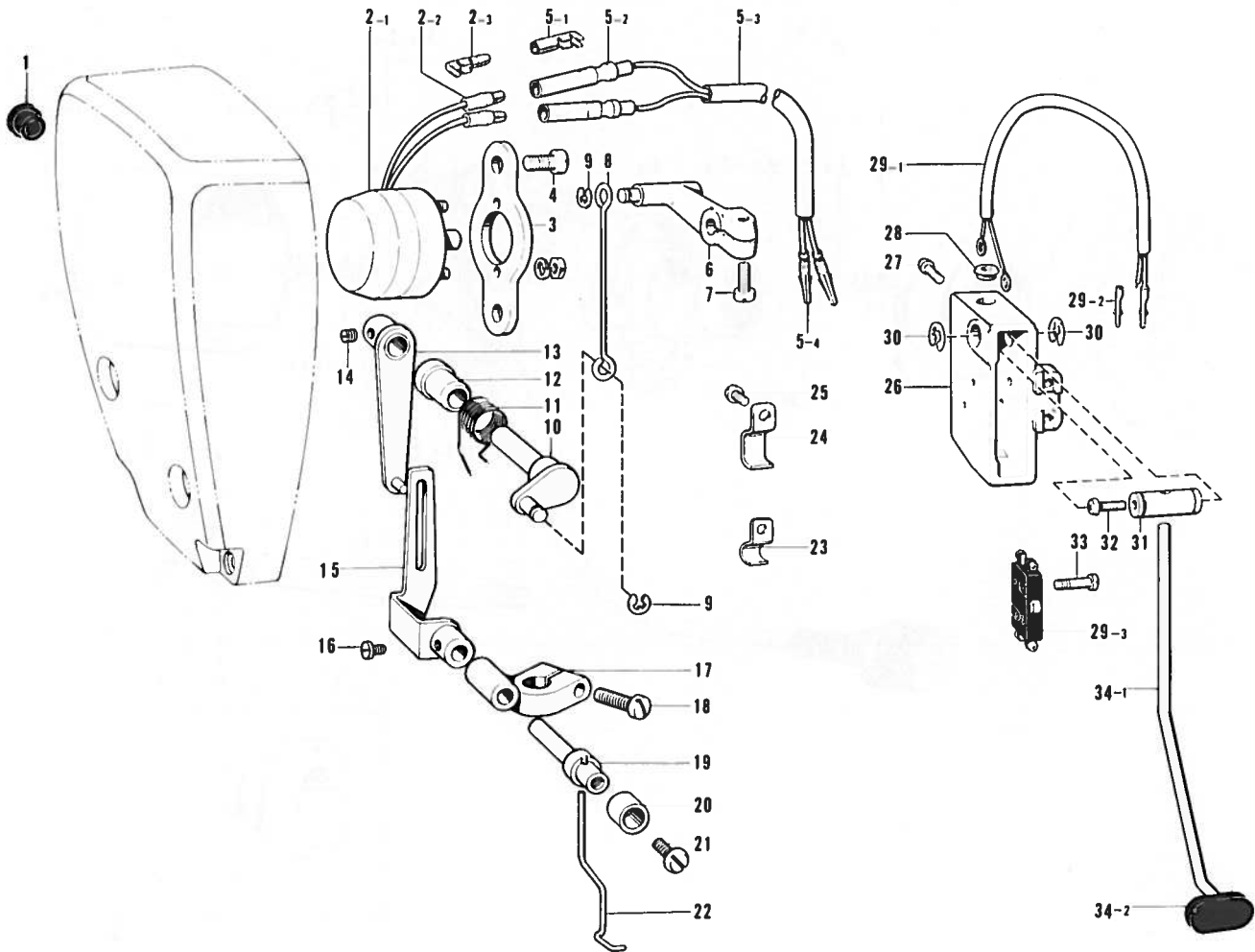

Ref. No.	Name of Parts	Q'ty	Parts No.	Assembly No.	Ref. No.	Name of Parts	Q'ty	Parts No.	Assembly No.
J- 1	Cord Bushing	1	146080-0-00		J-17	Thread Wiper Supporter	1	146093-0-01	
J- 2-1	Thread Wiper Solenoid	1	146083-0-00	J-2	J-18	Screw	1	009681-4-14	
J- 2-2	Insulated Cover	2	146085-0-00	Thread Wiper Solenoid Assembly 146082-0-00	J-19	Thread Wiper Stud	1	146092-0-01	
J- 2-3	Plug	2	146084-0-00		J-20	Thread Wiper Stud Collar	1	146288-0-01	
J- 3	Solenoid Set Plate	1	146081-0-01		J-21	Screw	1	001670-5-14	
J- 4	Screw	2	009680-8-12		J-22	Thread Wiper	1	151436-0-00	
J- 5-1	Insulated Sleeve	2	146098-0-00	J-5	J-23	Cord Holder	2		
J- 5-2	Receptacle	2	146097-0-00	Thread Wiper Cord Assembly	J-24	Cord Holder	2		
J- 5-3	Thread Wiper Cord	1	146096-0-00		J-25	Screw	2		
J- 5-4	Terminal Pin	2	143549-0-00		J-26	Reverse Switch Case	1	146120-0-01	
J- 6	Solenoid Lever	1	146086-0-01		J-27	Screw	2	009671-0-12	
J- 7	Screw	1	009671-0-13		J-28	Bushing	1	146080-0-00	
J- 8	Wire Link	1	146087-0-01		J-29-1	Reverse Switch Cord	1		J-29
J- 9	Stop Ring	2	048025-3-42		J-29-2	Terminal Pin	2		Switch
J-10	Thread Wiper Crank	1	146088-0-01		J-29-3	Micro Switch	1	140643-0-00	
J-11	Spring	1	146089-0-01		J-30	Stop Ring	2	048080-3-42	
J-12	Bushing	1	146079-0-01		J-31	Actuator Pin	1	146125-0-01	
J-13	Thread Wiper Lever	1	151434-0-01		J-32	Screw	1	009681-4-14	
J-14	Screw	2	102716-0-02		J-33	Screw	2	146124-0-01	
J-15	Grooved Link	1	151435-0-01		J-34-1	Actuator Bar	1	146127-0-01	J-34
J-16	Screw	1	111443-0-01		J-34-2	Actuator	1	146128-0-00	Reverse Finger 146126-0-01

※Parts of J-1~J-26 are Thread Wiper (-500).

※Parts of J-27~J-34 are Quick Back Switch Mechanism (-500-600).

K. Synchronizer (-500-600)

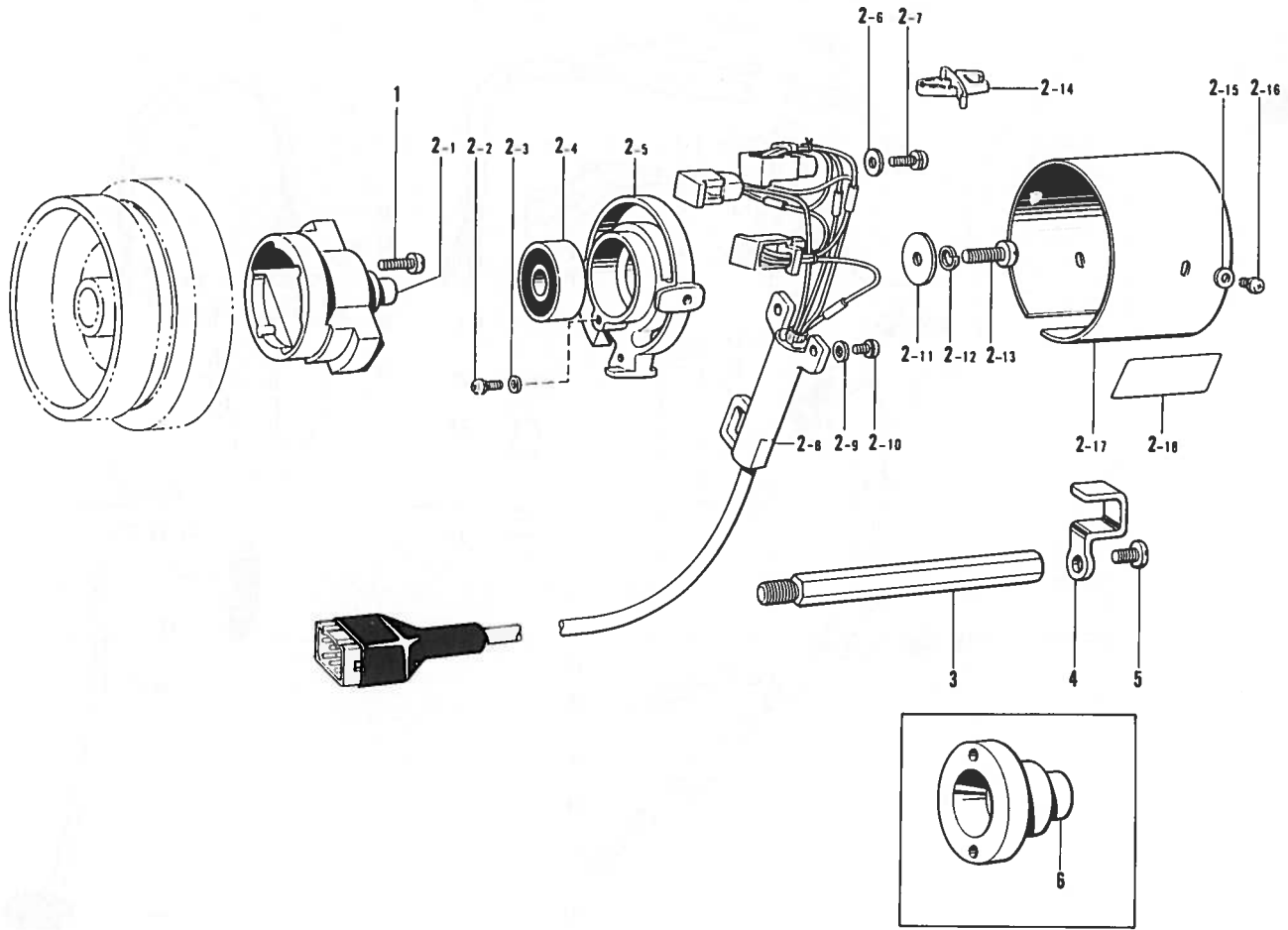

Ref. No.	Name of Parts	Q'ty	Parts No.	Assembly No.	Ref. No.	Name of Parts	Q'ty	Parts No.	Assembly No.
K-1	Screw	2	009711-4-12	K-2 Synchronizer Assembly	K-2-12	Washer	1	028060-2-34	K-2 Synchronizer Assembly
K-2-1	Magnet Stud	1			K-2-13	Screw	1	216880-0-01	
K-2-2	Screw	1	215083-0-01		K-2-14	Cord Holder	1		
K-2-3	Washer	1	025030-3-35		K-2-15	Washer	2	025040-1-35	
K-2-4	Bearing	1			K-2-16	Screw	2	215080-0-01	
K-2-5	Hole IC Holder	1			K-2-17	Synchronizer Cover	1		
K-2-6	Washer	3	025040-3-35		K-2-18	Label	1		
K-2-7	Screw	3	217093-0-01		K-3	Synchronizer Holder Bar	1	151438-0-01	
K-2-8	Hole IC with Cord	1	218953-0-01		K-4	Synchronizer Holder	1	151437-0-01	
K-2-9	Washer	2	025040-1-35		K-5	Screw	1	009670-6-12	
K-2-10	Screw	2	215080-0-01		K-6	Slip Ring Support	1		
K-2-11	Washer	1	025060-3-35						

Q. Valve Box (-500-600)

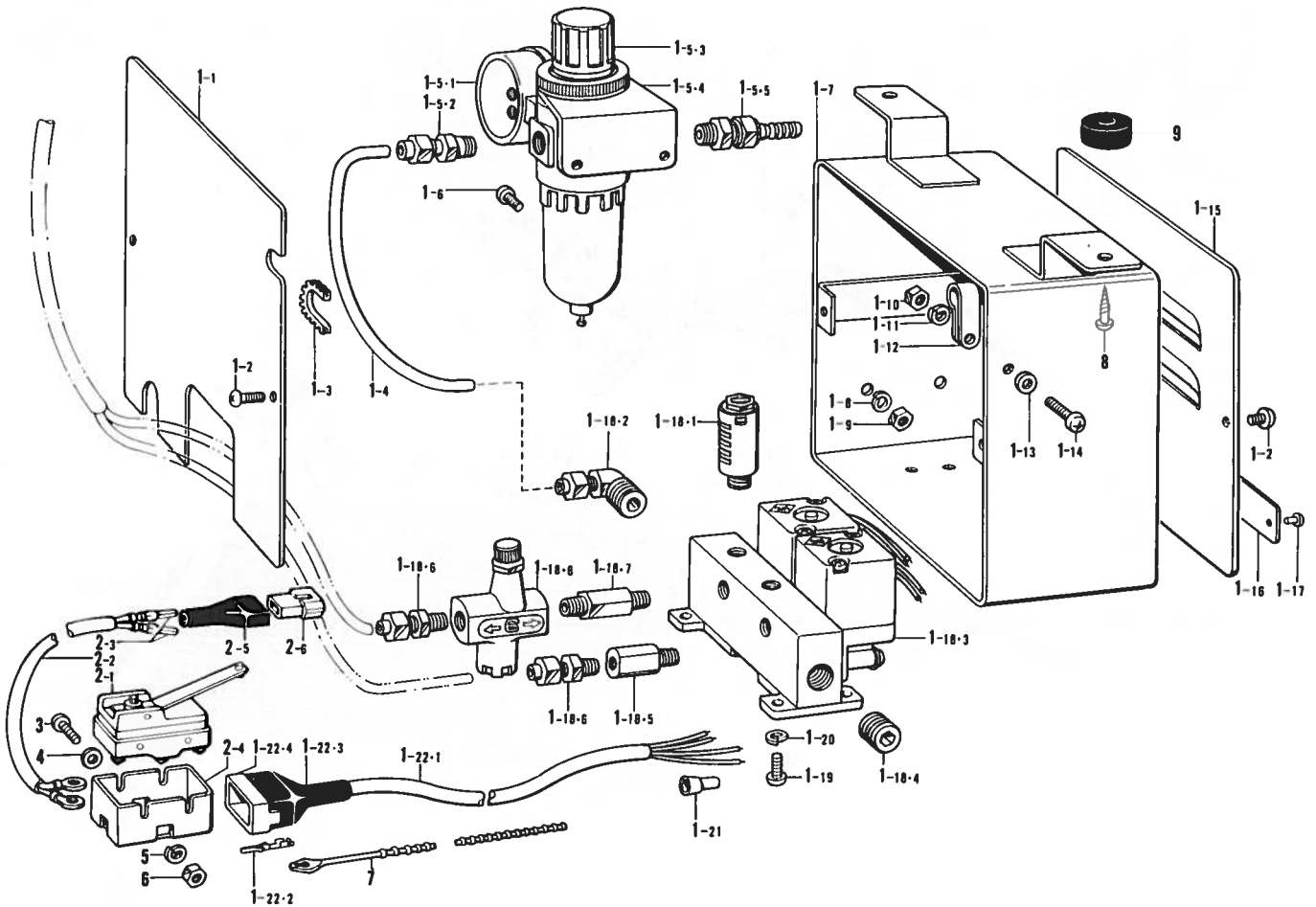

Ref. No.	Name of Parts	Q'ty	Parts No.	Assembly No.	Ref. No.	Name of Parts	Q'ty	Parts No.	Assembly No.
Q-1-1	Back Cover	1		Q-1 Air Control Box 149539-0-01	Q-1-18-7	Speed Control Connector	1	142037-0-00	Q-1-18 Solenoid Valve Assembly 149543-0-01
Q-1-2	Screw	4	008400-5-64		Q-1-18-8	Speed Controller	1	142038-0-01	
Q-1-3	Nylon Bushing	1	146171-0-00		Q-1-19	Screw	4	002401-2-03	Q-1 Air Control Box 149539-0-01
Q-1-4	Air Tube	1	140540-0-00		Q-1-20	Nut	4	021400-1-03	
Q-1-5-1	Presser Gauge	1			Q-1-21	Washer	4	028040-2-43	
Q-1-5-2	Connector	1	142349-0-00		Q-1-22	Washer	4	025040-1-33	Q-1-24 Valve Cord Assembly 149545-0-01
Q-1-5-3	Plastic Bottol	1	143960-1-01		Q-1-23	Connector	4	206755-0-00	
Q-1-5-4	Air Unit Holder Plate	1	143962-0-01		Q-1-24-1	Valve Cord	1		Q-2 Presser Foot Lifter Cord Assembly 146160-0-01
Q-1-5-5	Air Tube Connector	1	140678-0-00		Q-1-24-2	Terminal Pin	4	143549-0-00	
Q-1-6	Screw	2	002501-0-64		Q-1-24-3	Connector Cap	1	145596-0-01	
Q-1-7	Valve Case	1			Q-1-24-4	6P Connector	1	146118-0-00	Q-2 Presser Foot Lifter Cord Assembly 146160-0-01
Q-1-8	Washer	2	028050-2-43		Q-2-1	Micro Switch	1	140948-0-01	
Q-1-9	Nut	2	021500-1-63		Q-2-2	Presser Foot Lifter Cord	1		
Q-1-10	Nut	1	021300-1-03		Q-2-3	Terminal Pin	2	143549-0-00	Q-2 Presser Foot Lifter Cord Assembly 146160-0-01
Q-1-11	Washer	1	028030-2-43		Q-2-4	Cover	1	140950-0-00	
Q-1-12	Cord Holder	1	149547-0-00		Q-2-5	Connector Cap	1	143489-0-01	
Q-1-13	Washer	1	025030-1-33		Q-2-6	Nylon Connector	1	143488-0-01	
Q-1-14	Screw	1	002301-0-03	Q-3	Screw	2	002303-0-06		
Q-1-15	Rear Cover	1		Q-4	Washer	2	025030-2-33		
Q-1-16	Name Plate	1		Q-5	Washer	2	028030-2-43		
Q-1-17	Rivet	2		Q-6	Nut	2	021300-1-03		
Q-1-18-1	Silencer	2	140682-0-01	Q-7	Bead Band	1	144189-0-01		
Q-1-18-2	1/4" Elbow	1	140538-0-00	Q-8	Screw	2	031483-2-03		
Q-1-18-3	Solenoid Valve	1	149544-0-01	Q-9	Rubber Cushion	2	115018-0-01		
Q-1-18-4	1/4" Cap	1	140542-0-01						
Q-1-18-5	Valve Connector	2	140539-0-00						
Q-1-18-6	1/4" Connector	2	140543-0-00						

* This Valve Box is available to BROTHER specification.

R. Presser Lifter and Treadle Mechanism

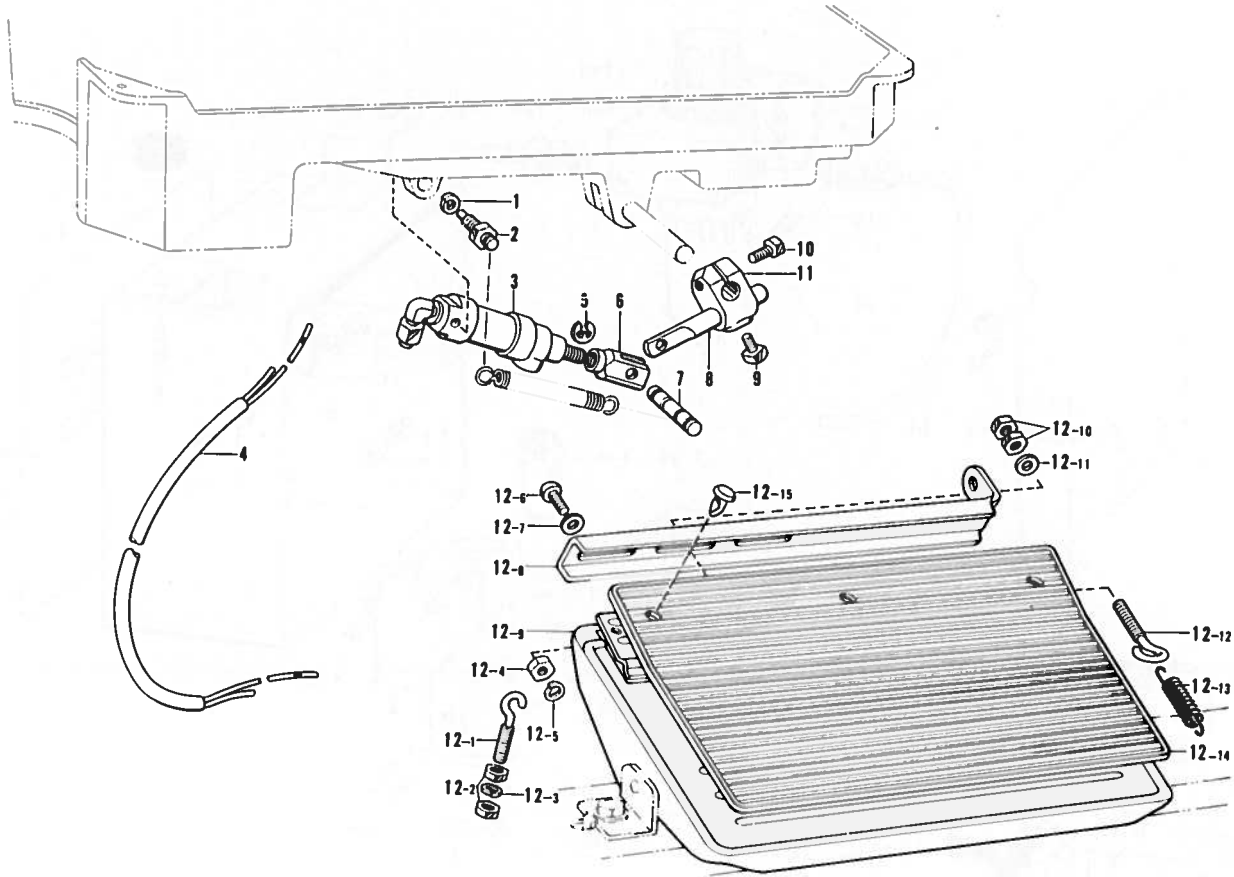

Ref. No.	Name of Parts	Q'ty	Parts No.	Assembly No.	Ref. No.	Name of Parts	Q'ty	Parts No.	Assembly No.
R- 1	Washer	2	028060-2-40		R-12- 3	Washer	1	028040-2-43	R-12 Treadle Assembly 146175-0-01
R- 2	Screw	2	147141-0-01		R-12- 4	Nut	2	021060-2-06	
R- 3	Presser Foot Cylinder	1	146157-0-01		R-12- 5	Washer	2	028060-2-40	
R- 4	Air Tube Assembly	1	146159-0-01		R-12- 6	Screw	2	001061-6-06	
R- 5	Stop Ring	2	048040-3-42		R-12- 7	Washer	2	025060-2-36	
R- 6	Piston Rod Joint	1	140627-0-01		R-12- 8	Treadle Connector	1		
R- 7	Pin	1	146986-0-01		R-12- 9	Treadle	1		
R- 8	Piston Drive Link	1	140668-0-01		R-12-10	Nut	2	021500-1-04	
R- 9	Bolt	1	100463-0-01		R-12-11	Washer	1	025050-2-33	
R-10	Bolt	1	017762-0-13		R-12-12	Spring Hook	1	140953-0-01	
R-11	Knee Lifter Joint	1	146039-0-01		R-12-13	Spring	1	146178-0-01	
R-12-1	Adjusting Hook	1	140947-0-01	R-12 Treadle Assembly 146175-0-01	R-12-14	Rubber	1	109268-0-01	
R-12-2	Nut	2	212251-0-01		R-12-15	Clip	3	146358-0-01	

S. Control Box

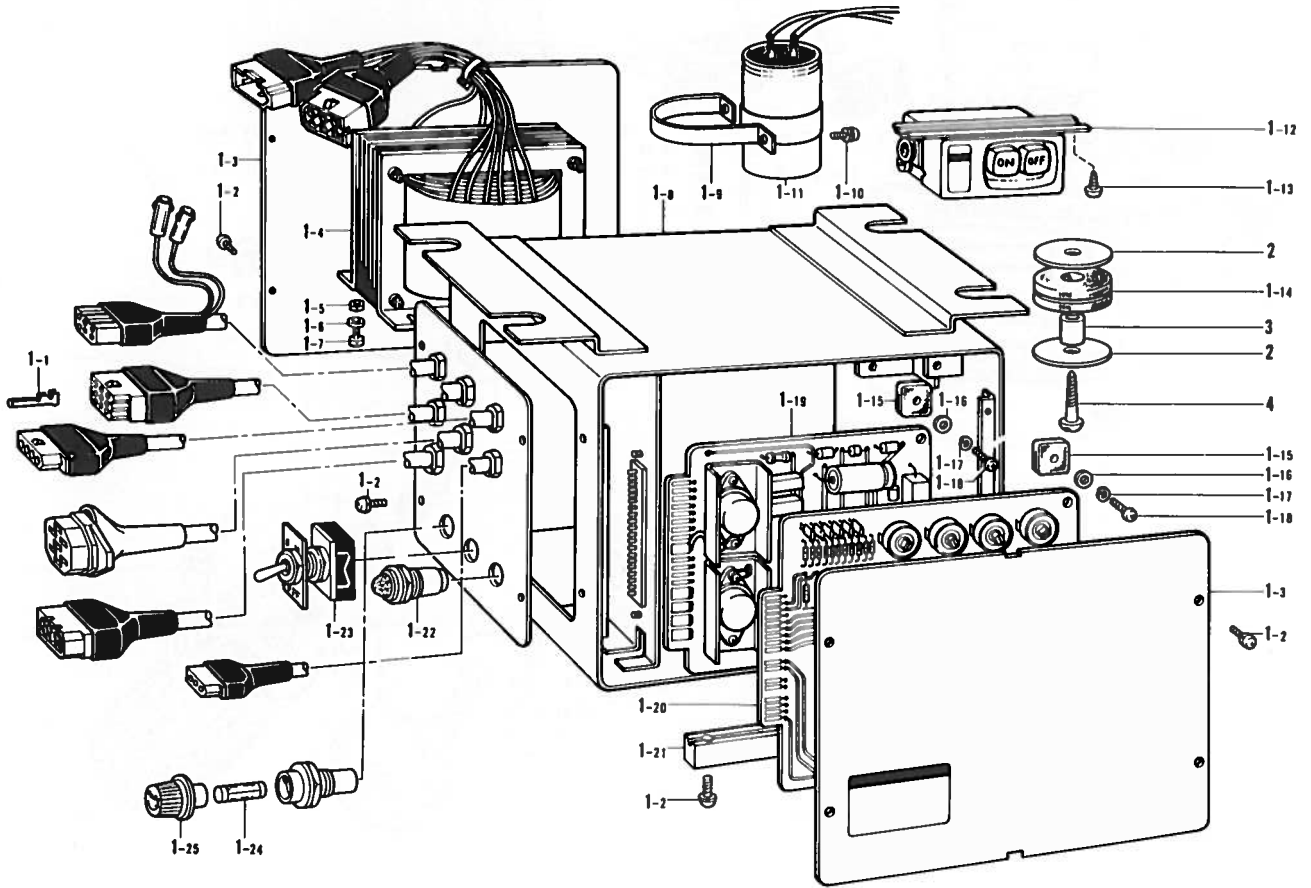

Ref. No.	Name of Parts	Q'ty	Parts No.	Assembly No.	Ref. No.	Name of Parts	Q'ty	Parts No.	Assembly No.
S-1- 1	Terminal Pin	27	216373-0-01	S-1 Control Box Assembly	S-1-15	Insulator Rubber	2	216351-0-00	S-1 Control Box Assembly
S-1- 2	Screw	16	215080-0-01		S-1-16	Washer	4	025030-3-35	
S-1- 3	Control Box Front Cover Plate	2	218819-0-01		S-1-17	Washer	2	028030-2-43	
S-1- 4	Transformer	1			S-1-18	Screw	4	002300-8-05	
S-1- 5	Nut	4	218823-0-01		S-1-19	Printed Circuit Board	1		
S-1- 6	Washer	4	025040-2-35		S-1-20	Printed Circuit Board	1		
S-1- 7	Screw	4	216870-0-01		S-1-21	Mounting Rail	2	218821-0-01	
S-1- 8	Control Box	1			S-1-22	Pilot Lamp	1		
S-1- 9	Condenser Set Plate	1			S-1-23	Pilot Lamp Switch	1	216905-0-01	
S-1-10	Screw	2			S-1-24	5A Fuse	1	215822-0-00	
S-1-11	Condenser	1			S-1-25	Fuse Holder	1	215387-0-01	
S-1-12	3P Push Button Switch	1	213794-0-01		S-2	Washer	8	214344-0-01	
S-1-13	Screw	2	031451-6-03		S-3	Collar	4	216346-0-01	
S-1-14	Cushion Rubber	4	216345-0-00		S-4	Screw	4	031624-0-05	

T. Motor (Part 1)

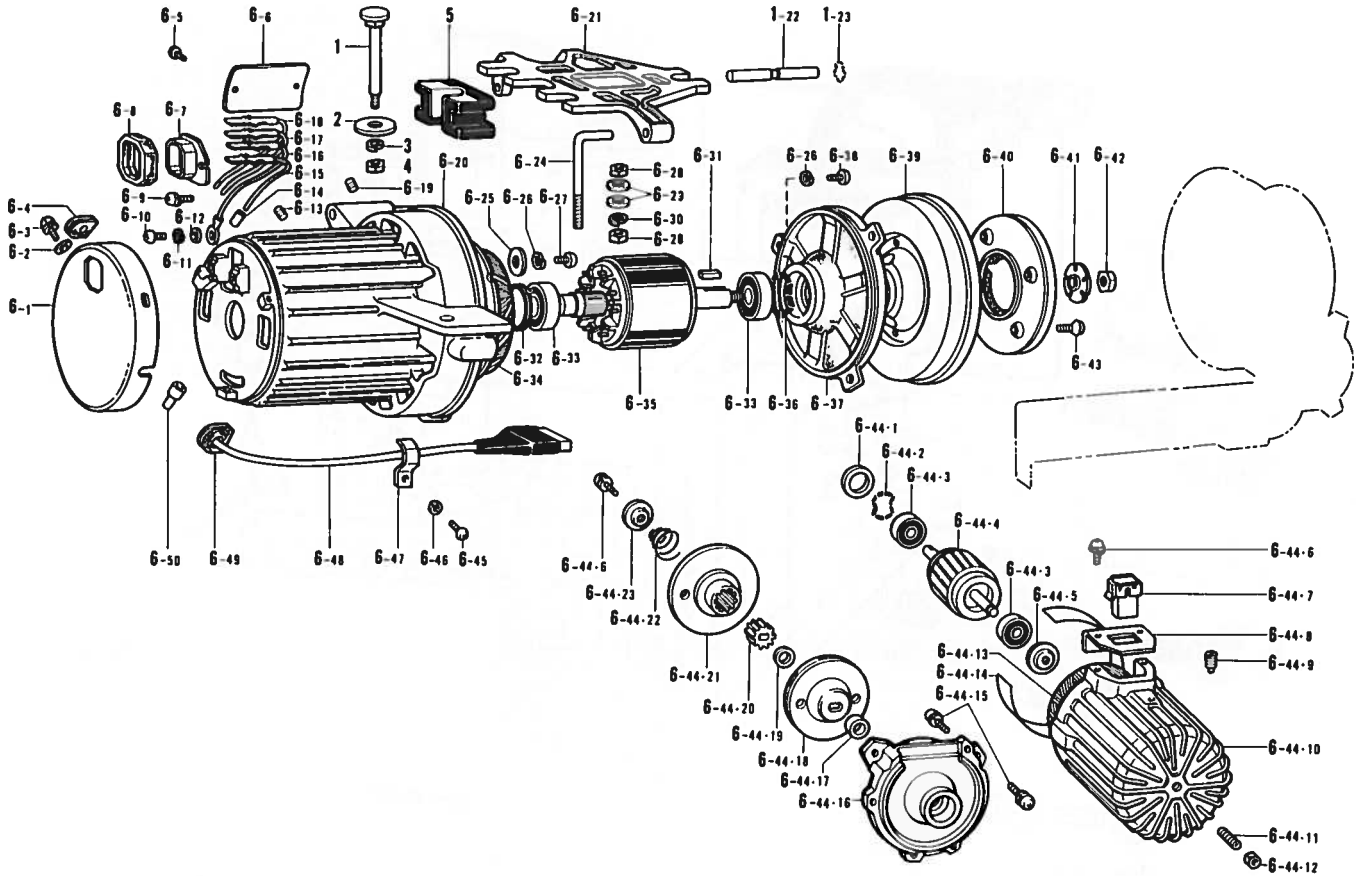

Ref. No.	Name of Parts	Q'ty	Parts No.	Assembly No.	Ref. No.	Name of Parts	Q'ty	Parts No.	Assembly No.
T-1	Bolt	3	210973-0-01		T-6-34	Stator	1		
T-2	Washer	3	213650-0-01		T-6-35	Rotor	1		
T-3	Washer	3	028080-2-43		T-6-36	Washer	1	206156-0-01	
T-4	Nut	3	021080-1-06		T-6-37	Bracket	1	218871-0-01	
T-5	Vibration Absorbing Rubber	3	213646-0-01		T-6-38	Screw	3	002501-6-05	
T-6-1	Frame Cover	1	218863-0-01		T-6-39	Fly Wheel	1		T-6
T-6-2	Washer	3	025050-2-35		T-6-40	Clutch Lining #4	1	218873-0-00	Motor
T-6-3	Screw	3	211528-0-01		T-6-41	Washer	1	210941-0-02	Assembly
T-6-4	Rubber Pad #72	1	218865-0-01		T-6-42	Nut	1	210942-0-02	
T-6-5	Pin	2	200084-0-02		T-6-43	Screw	4	214897-0-01	
T-6-6	Model Plate	1			T-6-44-1	Washer	2	218913-0-01	
T-6-7	7P Socket	1	213748-0-01		T-6-44-2	Washer	3	218870-0-01	
T-6-8	7P Socket Cover 1	1	218862-0-01		T-6-44-3	Bearing 608VV	2	072060-8-60	
T-6-9	Screw	2	008400-8-06		T-6-44-4	Roter	1		
T-6-10	Screw	1	002401-0-63		T-6-44-5	Roter Push Plate	1	218910-0-00	
T-6-11	Washer	1	028040-2-43		T-6-44-6	Screw	3	215080-0-01	
T-6-12	Nut	1	025040-1-73		T-6-44-7	3P Plug	1	216299-0-01	
T-6-13	Screw	1	013080-8-13		T-6-44-8	Plug Set Plate	1	216300-0-01	
T-6-14	Vinyl Cap for Lead Wire	2	218951-0-01		T-6-44-9	Screw	1	216286-0-01	
T-6-15	Lead Wire (White)		218861-0-01		T-6-44-10	Sub Motor Frame #55	1	218911-0-01	
T-6-16	Lead Wire for Earth	1			T-6-44-11	Screw	1	012061-8-22	T-6-44
T-6-17	Lead Wire (Red)	1	218861-0-02		T-6-44-12	Nut	1	021060-3-05	Sub Motor
T-6-18	Lead Wire (Black)	1	218861-0-03		T-6-44-13	Stator	1		Assembly
T-6-19	Screw	1	011060-6-13		T-6-44-14	Insulator Paper	2	216284-0-00	
T-6-20	Frame #54	1	218831-0-01		T-6-44-15	Screw	3	211528-0-01	
T-6-21	Base	1	218874-0-01		T-6-44-16	Bracket	1	218912-0-00	
T-6-22	Pin	1	218875-0-01		T-6-44-17	Collar	1	218922-0-01	
T-6-23	Washer	1	213765-0-01		T-6-44-18	Clutch Plate	1	218916-0-01	
T-6-24	Bolt Adjusting Rod	1	210965-0-01		T-6-44-19	Washer	1	218921-0-01	
T-6-25	Washer	3	213752-0-01		T-6-44-20	Selation	1	217280-0-01	
T-6-26	Spring Washer	6	028050-2-43		T-6-44-21	Round Plate	1	218918-0-01	
T-6-27	Screw	3	218905-0-01		T-6-44-22	Spring	1	218919-0-01	
T-6-28	Nut	2	021100-2-06		T-6-44-23	Washer	1	218920-0-00	
T-6-29	Washer	2	025100-2-36		T-6-45	Screw	1	002500-8-06	
T-6-30	Washer	1	028100-2-43		T-6-46	Spring Washer	1	028050-2-43	
T-6-31	Key	1	210940-0-00		T-6-47	Cord Holder	1	218866-0-01	
T-6-32	Rubber Washer 708×35×40RU	1	210938-0-01		T-6-48	Plug for Sub Motor	1	218867-0-01	
T-6-33	Bearing 6203VV	2	072620-3-60		T-6-49	Rubber Pad #71	1	218864-0-01	
					T-6-50	Crimp Connector	3	217169-0-00	

T. Motor (Part 2)

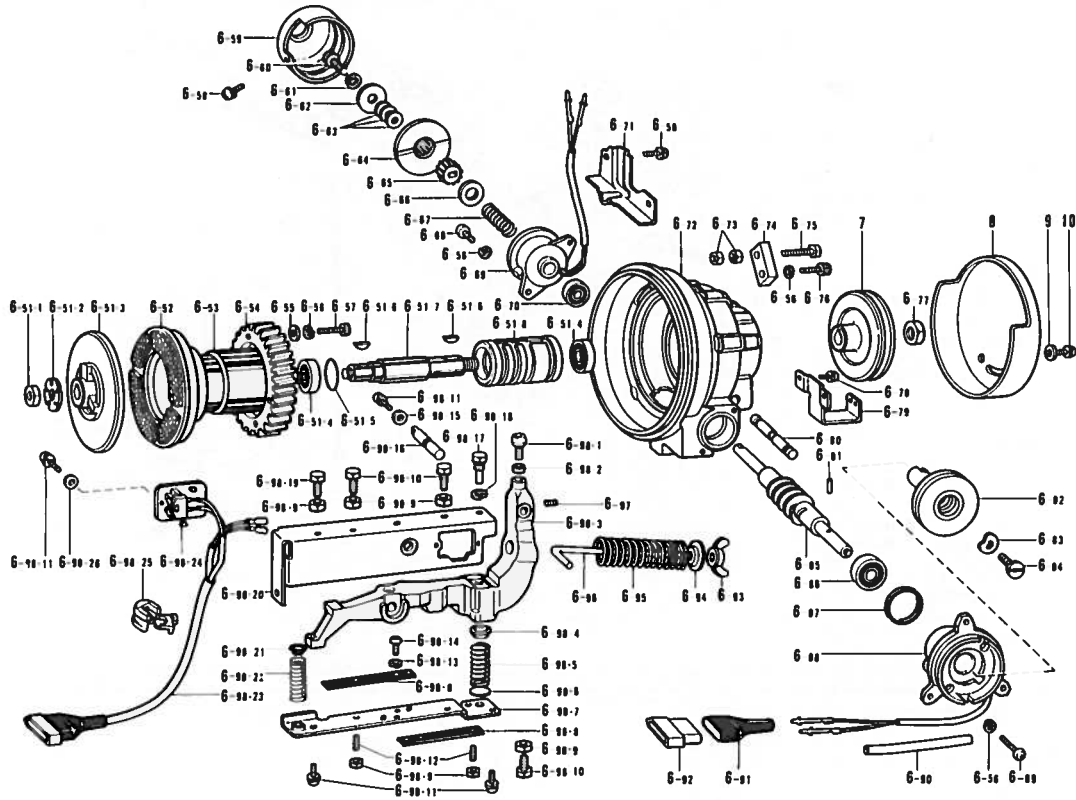

Ref. No.	Name of Parts	Q'ty	Parts No.	Assembly No.	Ref. No.	Name of Parts	Q'ty	Parts No.	Assembly No.
T-6-51-1	Nut	1	210942-0-02	T-6-51 Clutch Plate #8 Assembly 218877-0-01	T- 6-86	Bearing 6201VV	1	072620-1-61	T-6 Motor Assembly
T-6-51-2	Washer	1	210941-0-02		T- 6-87	Washer	1	216277-0-01	
T-6-51-3	Clutch Plate #6	1	213750-0-00		T- 6-88	Clutch Solenoid	1	218903-0-01	
T-6-51-4	Bearing 620VV	2	072620-2-60		T- 6-89	Screw	2	002503-5-05	
T-6-51-5	Washer	1	210948-0-01		T- 6-90	Vinyl Tube	1	216837-0-01	
T-6-51-6	Key	2	210421-0-00		T- 6-91	Plug Cover	1	216248-0-01	
T-6-51-7	Clutch Shaft	1	218878-0-00		T- 6-92	4P Plug	1	216247-0-01	
T-6-51-8	Clutch Shaft Supporter	1	218879-0-01		T- 6-93	Nut	1	206337-0-02	
T-6-52	Brake Lining	1	218882-0-00	T- 6-94	Spring Cap	1	213760-0-01		
T-6-53	Supporter for Clutch Shaft Supporter	1	290439-0-00	T- 6-95	Spring	1	218929-0-01		
T-6-54	Gear 1/2	1	216219-0-00	T- 6-96	Pedal Pressure Adjusting Screw	1	218928-0-01		
T-6-55	Washer	4	025050-1-35	T- 6-97	Screw	1	014061-0-22		
T-6-56	Washer	9	028050-2-43	T- 6-98- 1	Ball Screw	1	216225-0-01		
T-6-57	Screw	4	018502-5-22	T- 6-98- 2	Nut	1	218921-0-01		
T-6-58	Screw	4	215080-0-01	T- 6-98- 3	Clutch Lever	1	218924-0-01		
T-6-59	Brake Cover	1	218902-0-01	T- 6-98- 4	Spring Cap	1	216233-0-01		
T-6-60	Bolt	1	018401-4-22	T- 6-98- 5	Spring	1	218945-0-01		
T-6-61	Spring Washer	1	028040-2-43	T- 6-98- 6	Washer	1	216235-0-00		
T-6-62	Washer	1	218896-0-00	T- 6-98- 7	Clutch Lever Bottom Plate	1	218946-0-01		
T-6-63	Spacer	4	218860-0-01	T- 6-98- 8	Switch Presser Plate	2	216241-0-01		
T-6-64	Brake Disc	1	218895-0-01	T- 6-98- 9	Nut	6	021060-3-05		
T-6-65	Selation	1	217280-0-01	T- 6-98-10	Bolt	3	213913-0-01		
T-6-66	Washer	1	218894-0-01	T- 6-98-11	Screw	8	215080-0-01		
T-6-67	Spring	1	218893-0-01	T- 6-98-12	Screw	2	012061-2-22		
T-6-68	Screw	2	002501-6-05	T- 6-98-13	Spring Washer	2	028040-2-43		
T-6-69	Brake Solenoid	1	218915-0-01	T- 6-98-14	Screw	2	002400-6-05		
T-6-70	Bearing 608VV	1	072060-8-60	T- 6-98-15	Washer	1	025040-3-35		
T-6-71	Cord Holder	1	218930-0-01	T- 6-98-16	Pin	1	218926-0-01		
T-6-72	Bracket	1	218876-0-01	T- 6-98-17	Bolt	1	216232-0-01		
T-6-73	Nut	2	021060-3-05	T- 6-98-18	Washer	1	028060-2-43		
T-6-74	Space Adjusting Plate	1	218881-0-01	T- 6-98-19	Bolt	1	214002-0-01		
T-6-75	Bolt	1	219405-0-01	T- 6-98-20	Clutch Lever Cover	1	218925-0-01		
T-6-76	Bolt	1	018502-2-23	T- 6-98-21	Spring Cap	1	218927-0-01		
T-6-77	Nut	1	210240-0-01	T- 6-98-22	Spring	1	216230-0-01		
T-6-78	Screw	2	211528-0-01	T- 6-98-23	Micro Key Cord	1	218947-0-01		
T-6-79	Belt Cover Set Plate	1	216380-0-01	T- 6-98-24	Micro Switch	2	216236-0-01		
T-6-80	Pin	1	213757-0-02	T- 6-98-25	Bushing	1	212544-0-01		
T-6-81	Spring Pin	1	218952-0-01	T- 6-98-26	Washer	4	025040-1-35		
T-6-82	Clutch Plate #2	1	218885-0-01	T- 7	Pulley	1			
T-6-83	Washer	1	218891-0-01	T- 8	Belt Cover	1	215491-0-01		
T-6-84	Screw	1	218892-0-01	T- 9	Washer	2	025050-3-35		
T-6-85	Worm 1/2	1	218884-0-00	T-10	Screw	2	211528-0-01		
									T-6-98 Clutch Lever #8 Assembly 218923-0-01

Z. Accessories

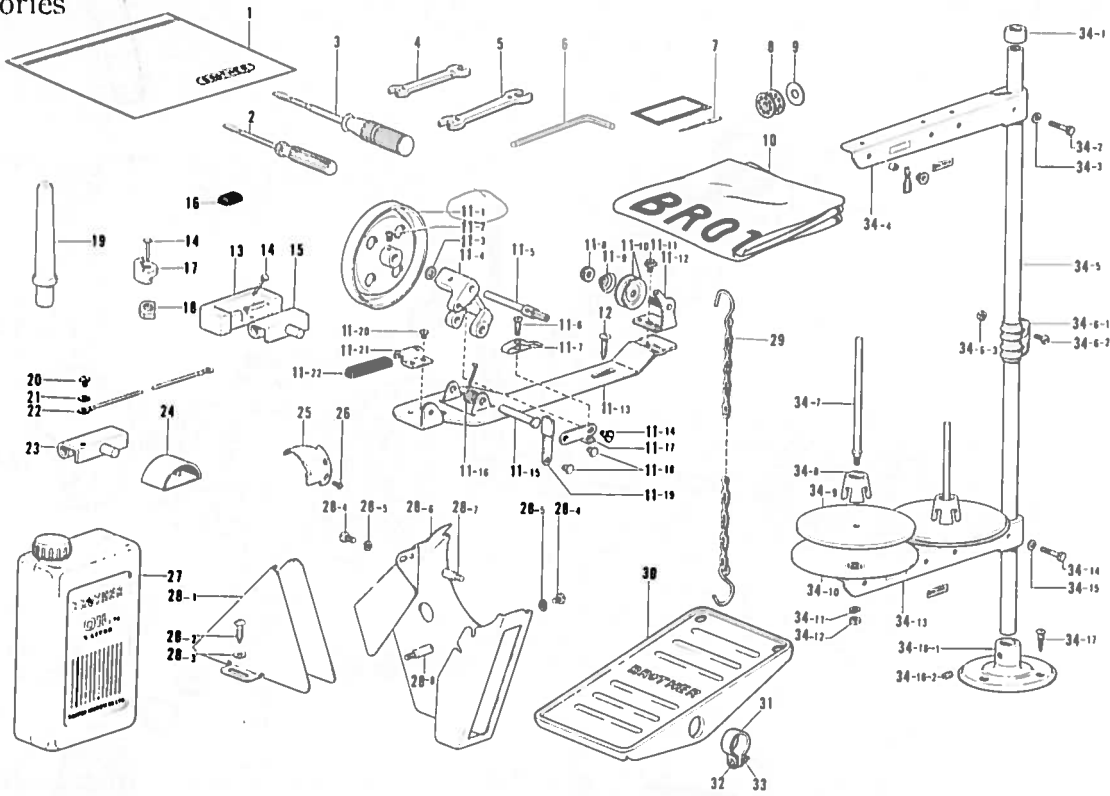

Ref. No.	Name of Parts	Q'ty	Parts No.	Assembly No.	Ref. No.	Name of Parts	Q'ty	Parts No.	Assembly No.
Z-1	Accessory Bag		122991-0-01		Z-19	Head Rest		100477-0-01	
Z-2	Screw Driver		142443-0-01		Z-20	Screw			
Z-3	Screw Driver		118837-0-01		Z-21	Washer			
Z-4	Spanner 6×7		107779-0-01		Z-22	Earth Wire			
Z-5	Spanner 8×9		100887-0-01		Z-23	Head Hinge			
Z-6	Spanner		146049-0-01		Z-24	Movable Knife Case			
Z-7	Needle DB×1		100265-0-31		Z-25	Movable Knife			
Z-8	Bobbin				Z-26	Screw			
Z-9	Bobbin Case Sheet				Z-27	Oil Tank		145277-1-03	
Z-10	Head Cover		144222-0-01		Z-28-1	Belt Cover D			
Z-11-1	Bobbin Winder Wheel Assembly				Z-28-2	Screw		100666-0-02	
Z-11-2	Screw		100366-0-02		Z-28-3	Washer		025750-1-32	Z-28
Z-11-3	Washer				Z-28-4	Screw		009680-8-12	Belt Cover Assembly
Z-11-4	Bobbin Winder Wheel Shaft Bushing				Z-28-5	Washer		028680-2-42	147895-0-11
Z-11-5	Bobbin Winder Shaft		117970-0-01		Z-28-6	Belt Cover UA			
Z-11-6	Screw		100657-0-01		Z-28-7	Stud		147856-0-01	
Z-11-7	Bobbin Presser				Z-28-8	Stud		147855-0-01	
Z-11-8	Nut				Z-29	Chain Assembly			
Z-11-9	Spring		100401-0-01		Z-30	Foot Pedal			
Z-11-10	Tension Disc		145446-0-01	Z-11	Z-31	Foot Pedal Stopper			
Z-11-11	Screw			Bobbin Winder Assembly	Z-32	Screw			
Z-11-12	Bobbin Winder Wheel Guide Bracket Assembly			117963-0-01	Z-33	Nut			
Z-11-13	Bobbin Winder Wheel Bracket				Z-34-1	Cap			
Z-11-14	Screw		100659-0-01		Z-34-2	Bolt		017502-8-03	
Z-11-15	Pin				Z-34-3	Washer		025050-2-33	
Z-11-16	Spring		117969-0-01		Z-34-4	Thread Hanger Assembly		150192-0-01	
Z-11-17	Bobbin Presser Arm				Z-34-5	Pipe		150172-0-01	
Z-11-18	Pin		100661-0-01		Z-34-6-1	Joint		150173-0-01	Z-34-6
Z-11-19	Bobbin Presser Arm Bracket				Z-34-6-2	Screw		150202-0-01	Joint Assembly
Z-11-20	Screw		009679-3-12		Z-34-6-3	Nut		021500-1-03	150106-0-01
Z-11-21	Bobbin Winder Wheel Stopper Holder				Z-34-7	Spool Shaft		150179-0-01	
Z-11-22	Bobbin Winder Wheel Stopper		100662-0-01		Z-34-8	Spool Cushion		147060-0-01	Z-34
Z-12	Screw		100666-0-02		Z-34-9	Spool Mat		150182-0-00	Cotton Stand Assembly
Z-13	Rubber Hinge		143910-0-01		Z-34-10	Spool Stand Base		150180-0-00	150150-0-01
Z-14	Nail		109714-0-00		Z-34-11	Spring Washer		028050-2-43	
Z-15	Head Hinge		143882-0-01		Z-34-12	Nut		021500-1-03	
Z-16	Magnet		112525-0-00		Z-34-13	Spool Holder Assembly		150177-0-01	
Z-17	Oil Pan Cushion		146004-0-01		Z-34-14	Bolt		017502-8-03	
Z-18	Head Cushion		146003-1-01		Z-34-15	Washer		025050-2-33	
					Z-34-16-1	Cotton Stand Base		150189-0-01	Z-34-16
					Z-34-16-2	Screw		150181-0-01	Cotton Stand Base Assembly
					Z-34-17	Screw		031452-2-03	150139-0-01

* The details of included accessories are subject to change.



* Änderungen in der Aufstellung der mitgelieferten Zubehöre sind vorbehalten.

* Les détails des accessoires inclus sont sujets à des changements.

* Los detalles de los accesorios incluidos pueden variar.

Gauge parts (The gauge parts marked ※ cannot be used for the machine with thread wiper device.)

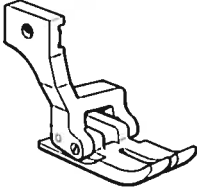
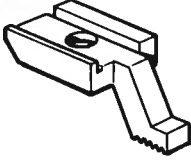
• Select the gauge parts (presser foot, upper feed dog, needle plate, feed dog) from those shown below.

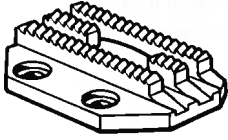
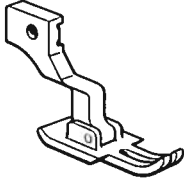
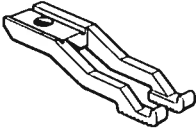
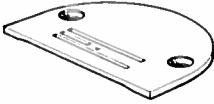
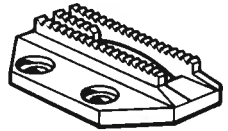
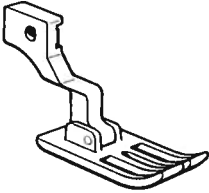
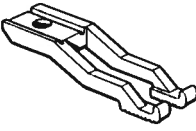
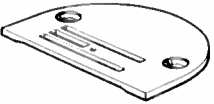
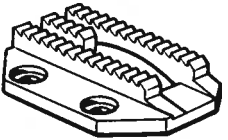
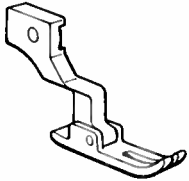
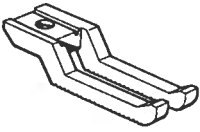
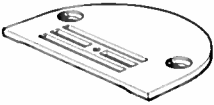
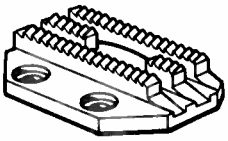
Assembly code	Presser foot	Upper feed dog	Needle plate	Feed dog
Replacement parts Group A 183041-0-01 For stretching Model DB2-B792-003	 151277-0-01	 151383-0-01	 151261-0-01	 151324-0-01
※ Replacement parts Group B 183042-0-01 For shirring Model DB2-B792-013	 151281-0-01	 151384-0-01	 151262-0-01	 151325-0-01
※ Replacement parts Group C 183043-0-01 For tucking prevention	 151286-0-01	 151384-0-01	 151263-0-01	 151326-0-01
※ Replacement parts Group D 183044-0-01 For materials which need large feeding capacity	 151288-0-01	 151385-0-01	 151261-0-01	 151324-0-01

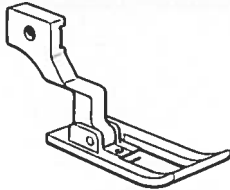
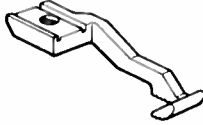
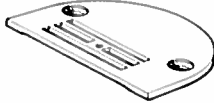
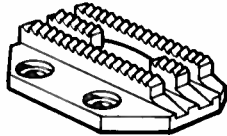
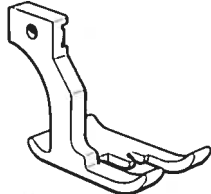
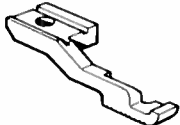
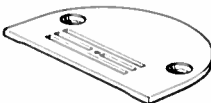
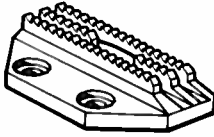
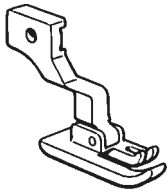
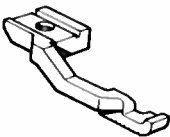
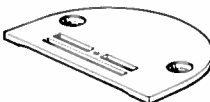
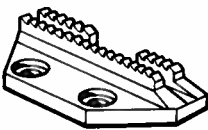
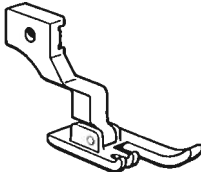
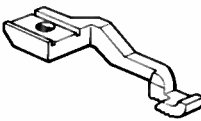
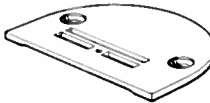
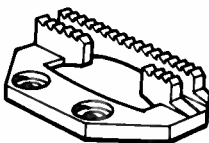
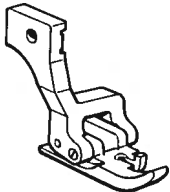
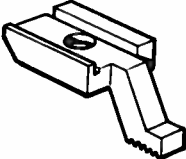
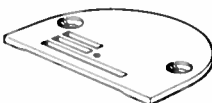
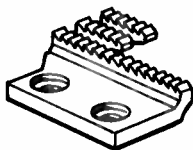
Assembly code	Presser foot	Upper feed dog	Needle plate	Feed dog
※ Replacement parts Group E 183045-0-01 For hemming	 151290-0-01	 151386-0-01	 151261-0-01	 151324-0-01
※ Replacement parts Group F 183046-0-01 For top stitching	 151292-0-01	 151387-0-01	 151264-0-01	 151327-0-01
✓ ※ Replacement parts Group GR 183047-0-01 For attachment of right zipper	 151293-0-01	 151388-0-01	 151265-0-01	 151328-0-01
✓ ※ Replacement parts Group GL 183048-0-01 For attachment of left zipper	 151296-0-01	 151389-0-01	 151266-0-01	 151329-0-01
Replacement parts Group H For pocket welting	 151299-0-01	 151383-0-01	 "Suisei" (Lot No. 10)	 "Suisei" (Lot No. 10)

DIFFERENT PARTS LIST

Ref. No.	Name of Parts	Sub Class		503		613	
		Motor Spec.	003	013	Brother	Efka	Brother
A-3	Face Plate		151430-0-01		151433-0-01		151430-0-01
A-12	Pretension Assembly		144502-0-01				
A-14	Rear Cover		151256-0-01	151257-0-01	151256-0-01		151257-0-01
A-25	Oil Cap		117936-0-01				
A-36	Oil Cap		104833-0-01		142271-0-01		
A-37	Oil Cap				104833-0-01		
A-40	Pretension Stud				146056-0-01		
A-41	Thread Guide Disc				147705-0-01		
A-42	Washer				146206-0-01		
A-43	Spring				146058-0-01		
A-44	Nut				146059-0-01		
A-45	Spring				146060-0-00		
A-46	Nut				105234-0-01		
A-47	Washer				025680-2-34		
A-48	Thread Guide Plate				146055-0-01		
B-11	Needle Bar		111462-0-01		145467-0-01		
B-34	Pulley		115244-0-01		148823-0-01		
B-36	Screw		104478-0-01				
B-53	Oil Stopper Assembly		144943-0-01				
B-54	Rotary Hook Assembly		116780-0-01		153131-0-01		
B-57	Bobbin		117132-0-01		100376-0-01		
B-58	Bobbin Case Sheet		140356-0-01				
B-59	Bobbin Presser Spring				148967-1-01		
B-60	Bobbin Case Assembly		100369-0-01		148350-1-01		
B-65	Needle Plate		151261-0-01	151262-0-01	151261-0-01		151262-0-01
C-14	Spring		145643-0-01	118753-0-01	145643-0-01		
C-18	Spring		151315-0-01				
C-19	Collar		151317-0-01				
C-20	Washer		025060-3-12				
C-21	Screw		009762-0-13				
C-23	Reverse Lever		151318-0-01				
C-24	Screw		009711-4-12				
C-25	Reverse Lever Shaft		151312-0-01				
C-50	Feed Dog		151324-0-01	151325-0-01	151324-0-01		151325-0-01

Ref. No.	Name of Parts	Sub Class		503		613	
		003	013	Brother	Efka	Brother	Efka
D-29	Upper Feed Regulator	151352-0-01		151352-0-01			
D-30	Screw	151403-0-01	013761-6-12	151403-0-01		013761-6-12	
D-54	Upper Feed Dog	151383-0-01	151384-0-01	151383-0-01		151384-0-01	
E - 1	Presser Foot Assembly	151277-0-01	151281-0-01	151277-0-01		151281-0-01	
E-18	Washer	151439-0-01					
E-19	Presser Bar Lifter Lever	145473-0-01					
E-20	Stop Ring	048040-3-42					
E-21	Tension Release Pin	145526-0-01				145691-0-01	
E-22	Washer					109763-0-02	
E-23	Tension Release Plate					151272-0-01	
E-24	Presser Bar Lifter Lever					145580-0-01	
E-25	Stop Ring					048040-3-42	
E-26	Spring					147197-0-01	
E-33	Knee Lifter Assembly	181427-0-01					
F - 6	Packing	151421-0-00	151422-0-00	151421-0-00		151422-0-00	
F-40	Oil Pan Assembly	181420-2-01				181430-2-01	
F-40-4	Oil Pan	149580-0-01				149581-0-01	
F-40-7	Spring	146038-0-01				146985-0-01	
F-40-8	Knee Lifter Shaft	146036-1-01				146069-0-01	
G-20	Collar					149087-0-01	
G-21	Reverse Lever					151319-0-01	
G-22	Spring					151316-0-01	
G-23	Reverse Lever Shaft					151313-0-01	
H-14	Thread Trimming Solenoid Bracket Assembly			150375-0-01	152187-0-01	150375-0-01	152187-0-01
H-14-5	Thread Trimming Solenoid Assembly			149108-0-01	152188-0-01	149108-0-01	152188-0-01
H-14-5-3	Terminal Pin			143549-0-00		143549-0-00	
H-19	Connector Cap			146119-0-00		146119-0-00	
H-20	Nylon Connector			145681-0-00		145681-0-00	
J - 5	Thread Wiper Cord Assembly			146095-0-00	146912-0-00		
J-23	Cord Holder					140647-0-01	
J-24	Cord Holder			142268-0-01			
J-25	Screw			009670-6-12			
J-29	Switch			146121-0-00	146913-0-00	146121-0-00	146913-0-00
J-29-2	Terminal Pin			143549-0-00		143549-0-00	
K-2	Synchronizer Assembly			218931-0-01		218931-0-01	

Ref. No.	Name of Parts	Sub Class		Motor Spec.		503		613	
		003	013	Brother	Efka	Brother	Efka		
K-6	Slip Ring Support					148825-0-01			148825-0-01
Z-8	Bobbin	117132-0-01		100376-0-01					
Z-9	Bobbin Case Sheet	140356-0-01							
Z-20	Screw			009680-6-13					
Z-21	Washer			025680-2-34					
Z-22	Earth Wire			145946-0-01					
Z-23	Head Hinge			145945-0-01					
Z-24	Movable Knife Case			145990-0-01					
Z-25	Movable Knife			145608-0-01					
Z-26	Screw			141542-0-01					
Z-29	Chain Assembly		149247-0-01			149247-0-01			
Z-30	Foot Pedal		147893-0-01						
Z-31	Foot Pedal Stopper		116016-0-01						
Z-32	Screw		001401-4-06						
Z-33	Nut		021400-1-06						
F-40-7	Spring Q'ty	1		2					

Ref. No.	Name of Parts	Parts No.	Sewing Speed			
			50 Hz		60 Hz	
			High Speed	Slow Speed	High Speed	Slow Speed
T-7	Pulley K- 75	216921-0-01			3550	165
	Pulley K- 80	217135-0-01			3850	180
	Pulley K- 85	216922-0-01	3400	160	4050	190
	Pulley K- 90	216923-0-01	3650	170	4300	205
	Pulley K- 95	217136-0-01	3850	180		
	Pulley K-100	216924-0-01	4050	190		
	Pulley K-105	216925-0-01	4250	200		

Ref. No.	Phase		3 Phase				1 Phase				
	Volt		220 V	380 V	400 V	400 V (Lamp tap 12 V)	110 V	220 V	240 V	240 V (Lamp tap 12 V)	240 V (W/O lamp tap)
Name of Parts											
S-1	Control Box Assembly	200	220970-0-01	220966-0-01	220965-0-01		220971-0-01	220972-0-01		221051-0-01	
		400					220974-0-01				
		500	220967-0-01	220968-0-01	220969-0-01		220975-0-01	220976-0-01	220977-0-01		
S-1-4	Transformer		219749-0-00	219501-0-00	219505-0-00		220001-0-00	219749-0-00	219744-0-00		
S-1-9	Condenser Set Plate						219746-0-01				
S-1-10	Screw						215080-0-01				
S-1-11	Condenser						220010-0-01	219745-0-01			
S-1-19	Printed Circuit Board	200/400					219698-0-01				
		500					220070-0-01				
S-1-20	Printed Circuit Board	200/500					219752-0-01				
		400					219699-0-01				
S-1-22	Pilot Lamp		216364-0-00				217249-0-00	216364-0-00			
T-6	Motor Assembly		219972-0-01	219497-0-01	219934-0-01	219507-0-01	219984-0-01	219733-0-01	219967-0-01	219726-0-01	219791-0-01
T-6-34	Stator		219485-0-01	219483-0-00	219935-0-00	219484-0-00	219985-0-00	219734-0-00	219968-0-00	219728-0-00	219792-0-00
T-6-35	Rotor		213802-0-01				217805-0-01				
T-6-39	Fly Wheel		218872-0-01				219729-0-01				
T-6-44	Sub Motor Assembly		219973-0-01	219499-0-01	219509-0-01		219986-0-01	219735-0-01	219730-0-01		
T-6-44-4	Rotor		218907-0-01				219235-0-01				
T-6-44-13	Stator		219488-0-00	219486-0-00	219487-0-00		219987-0-00	219736-0-00	219731-0-00		
T-6-16	Lead Wire for Earth		213792-0-01				213792-0-01				
T-6-15Q'ty	Lead Wire (White)		2				1				

INDEX

Parts No.	Ref. No.	Remark	Parts No.	Ref. No.	Remark	Parts No.	Ref. No.	Remark	Parts No.	Ref. No.	Remark
001061-6-06	R-12 6		011060-6-13	T-6-19		028030-2-43	Q-5		100401-0-01	Z-11-9	
001401-4-06	Z-32		011711-4-12	A-33			S-1-17		100402-0-04	A-28-1	
001670-5-14	J-21		012061-2-22	T-6-98-12		028040-2-43	H-14-2		100463-0-01	E-33-4	
001670-6-12	H-6		012061-8-22	T-6-44-11			Q-1-21			R-9	
002300-8-05	S-1-18		013080-8-13	T-6-13			R-12-3		100477-0-01	Z-19	
002301-0-03	Q-1-14		013679-4-12	H-14-16			T-6-11		100511-0-03	C-22	
002303-0-06	Q-3		013760-6-10	B-32			T-6-61		100573-0-01	B-4	
002400-6-05	T-6-98-14			B-39		028050-2-43	T-6-98-13		100645-0-03	H-14-10	
002401-0-63	T-6-10			D-57			Q-1-8			H-35	
002401-2-03	Q-1-19			D-77			T-6-26		100657-0-01	Z-11-6	
002500-8-06	T-6-45		013760-6-12	D-65			T-6-46		100659-0-01	Z-11-14	
002501-0-64	Q-1-6		013761-4-10	B-35			T-6-56		100661-0-01	Z-11-18	
002501-6-05	T-6-38			B-43			Z-34-11		100662-0-01	Z-11-22	
	T-6-68		013761-6-12	D-30		028060-2-34	K-2-12		100666-0-02	Z-12	
002503-5-05	T-6-89		014061-0-22	T-6-97		028060-2-40	R-1			Z-28-2	
003761-2-12	D-70		014680-6-22	H-26			R-12-5		100887-0-01	Z-5	
007401-0-12	H-14-1		017502-8-03	Z-34-2		028060-2-43	T-6-98-18		101482-0-01	C-3	
007500-8-12	G-8			Z-34-14		028080-2-43	T-3			D-37	
008400-5-64	Q-1-2		017762-0-13	E-33-2		028100-2-43	T-6-30		101487-0-00	B-28	
008400-8-06	T-6-9			R-10		028350-2-42	D-55		101706-0-01	C-52	
009660-7-12	H-43		018401-4-22	T-6-60			E-3			C-61	
	H-49		018502-2-23	T-6-76		028680-2-42	Z-28-5			C-63	
009670-5-12	F-3		018502-5-22	T-6-57		028680-2-43	D-84			C-69-2	
009670-5-13	F-25		021060-2-06	R-12-4		031451-6-03	S-1-13			H-22	
	G-1		021060-3-05	T-6-44-12		031452-2-03	Z-34-17		101706-0-03	B-41-2	
009670-6-12	B-13			T-6-73		031483-2-03	Q-8			B-48-1	
	C-13			T-6-98-9		031624-0-05	S-4		102538-0-02	F-12	
	J-25		021080-1-06	T-4		048025-3-42	J-9		102630-0-01	B-12	
	K-5		021100-2-06	T-6-28		048030-3-42	D-53-3		102716-0-02	J-14	
009670-6-14	A-27		021300-1-03	Q-1-10			H-2		102716-0-03	A-12-5	
009670-8-12	A-13			Q-6			H-14-9		103950-0-02	A-29	
	E-2		021400-1-03	Q-1-20			H-14-23		104449-0-01	A-4	
	F-36-9		021400-1-06	Z-33		048040-3-42	C-37-8			F-1	
009671-0-12	E-6-1		021500-1-03	Z-34-6-3			E-20		104450-0-01	A-5	
	J-27			Z-34-12			E-25		104451-0-01	A-16	
009671-0-13	J-7		021500-1-04	R-12-10		048080-3-42	G-3		104464-0-01	B-22	
009679-3-12	F-18		021500-1-63	Q-1-9		048090-3-42	G-15		104478-0-01	B-36	
	Z-11-20		021660-1-02	A-35			R-5		104520-0-00	B-46	
009680-5-12	D-64		021670-1-02	D-51-6		048080-3-42	J-30		104546-0-01	F-11	
	D-73		021670-2-03	H-10		048090-3-42	D-81		104547-0-01	F-10	
009680-6-12	H-9		025030-1-33	Q-1-13			H-14-15		104555-0-01	B-27	
	H-18		025030-2-33	Q-4		072060-8-60	T-6-44-3		104564-0-01	C-26	
009680-6-13	Z-20		025030-3-35	K-2-3			T-6-70		104566-0-01	F-17	
009680-7-13	A-7			S-1-16		072620-1-61	T-6-86		104619-0-02	E-33-3	
	F-39		025040-1-33	H-14-3		072620-2-60	T-6-51-4		104821-0-01	A-24	
	H-23			Q-1-22		072620-3-60	T-6-33		104829-1-01	A-38	
009680-8-12	J-4		025040-1-35	K-2-9		081002-6-70	B-26		104830-1-01	A-39	
	Z-28-4			K-2-15		081003-0-70	E-16		104832-0-01	A-15	
009681-0-12	D-50			T-6-98-26		081007-0-70	F-40-3		104833-0-01	A-36	
	D-53-6		025040-1-73	T-6-12		081014-6-70	F-9			A-37	
009681-0-14	A-11		025040-2-32	H-14-24		100022-0-04	F-40-11		104885-0-01	F-40-12	
009681-2-12	C-56		025040-2-35	S-1-6		100022-0-05	D-31		104908-0-01	C-55	
	C-68		025040-3-35	K-2-6		100058-0-01	D-69-11		105095-0-01	D-69-12	
	H-36			T-6-98-15		100080-0-03	C-49		105234-0-01	A-46	
009681-4-14	J-18		025050-1-35	T-6-55		100134-0-01	A-28-7		106147-0-01	E-12	
	J-32		025050-2-33	R-12-11		100136-0-01	A-28-9		107149-0-01	B-67	
009681-6-12	C-65-2			Z-34-3		100242-0-03	H-14-7		107155-0-01	B-45	
009711-2-12	C-59			Z-34-15		100260-0-01	B-6			D-52	
009711-4-12	C-24		025050-2-35	T-6-2			B-8		107407-0-03	B-55	
	K-1		025050-3-35	T-9		100265-0-31	B-1		107682-0-01	D-42	
009751-6-12	D-1		025060-2-36	R-12-7			Z-7		107779-0-01	Z-4	
	D-11		025060-3-32	C-20		100315-0-02	D-69-6		108520-0-01	A-17	
	D-18		025060-3-35	K-2-11		100328-0-01	C-15		108549-0-01	C-17-2	
	D-41		025100-1-30	C-29		100366-0-01	D-16			D-61-2	
009761-4-12	G-18		025100-2-36	T-6-29		100366-0-02	Z-11-2		108749-0-01	C-35	
009762-0-13	C-21		025680-1-33	H-24		100367-0-01	B-56			D-71	
009781-4-12	H-15		025680-2-34	A-47		100369-0-01	B-60		108801-0-01	F-15	
009781-8-12	D-28			Z-21		100376-0-01	B-57			F-22	
	G-6		025750-1-32	Z-28-3			Z-8		108802-0-01	F-19	
009782-5-12	G-10		028030-2-43	Q-1-11		100398-0-01	A-28-5			F-21	

Parts No.	Ref. No.	Remark	Parts No.	Ref. No.	Remark	Parts No.	Ref. No.	Remark	Parts No.	Ref. No.	Remark
108802-0-01	F-28		120023-0-01	D-80		143910-0-01	Z-13		146004-0-01	Z-17	
108809-0-01	B-10		120263-0-02	D-32		143959-1-03	Q-1-5		146036-1-01	F-40-8	
109151-1-01	C-17-1		120305-0-01	D-69-7		143960-1-01	Q-1-5-3		146037-0-01	F-40-10	
	D-61-1		120311-0-02	A-1		143962-0-01	Q-1-5-4		146038-0-01	F-40-7	
109153-0-01	C-45		121007-0-01	B-47		144075-0-01	D-56		146039-0-01	E-33-1	
109171-0-01	F-16		122771-0-01	B-64-2		144189-0-01	Q-7			R-11	
109173-0-01	B-61		122991-0-01	Z-1		144222-0-01	Z-10		146040-0-01	F-40-1	
109203-0-01	D-66		140004-0-01	B-9-8		144458-0-01	H-40		146049-0-01	Z-6	
109268-0-01	R-12-14		140092-0-01	D-15		144502-0-01	A-12		146055-0-01	A-48	
109405-0-01	F-4-2		140356-0-01	B-58		144504-0-01	A-12-3		146056-0-01	A-40	
109714-0-00	Z-14			Z-9		144505-0-00	A-12-4		146058-0-01	A-43	
109763-0-02	E-22		140378-0-01	B-37		144712-0-01	C-5-2		146059-0-01	A-44	
110087-0-01	E-33-6		140381-0-01	B-44		144741-0-01	A-28-2		146060-0-00	A-45	
110367-0-01	B-19		140407-0-01	E-7		144869-0-01	F-36-7		146069-0-01	F-40-8	
110558-0-01	D-79		140480-0-01	F-40-5		144872-0-01	F-38		146079-0-01	J-12	
110562-0-01	D-17-2		140503-0-01	E-33-8		144874-0-01	F-36-8		146080-0-00	H-16	
	D-40-3		140518-0-01	F-40-2		144875-0-01	F-36-3			J-1	
110563-0-01	D-40-2		140538-0-00	Q-1-18-2		144876-0-01	D-59			J-28	
111443-0-01	J-16		140539-0-00	Q-1-18-5			F-36-2		146081-0-01	J-3	
111462-0-01	B-11		140540-0-00	Q-1-4		144878-0-01	F-36-4		146082-0-00	J-2	
111863-0-01	B-18		140542-0-01	Q-1-18-4		144943-0-01	B-53		146083-0-00	J-2-1	
111865-0-01	F-20		140543-0-00	Q-1-18-6		145277-1-03	Z-27		146084-0-00	J-2-3	
112467-0-02	F-36-1		140553-0-01	B-3		145446-0-01	A-28-6		146085-0-00	J-2-2	
112525-0-00	Z-16		140627-0-01	G-13			Z-11-10		146086-0-01	J-6	
113956-0-01	D-69-8			R-6		145459-1-01	B-24		146087-0-01	J-8	
114294-0-01	A-28-3		140643-0-00	J-29-3		145461-1-01	B-33		146088-0-01	J-10	
114561-0-01	B-64-3		140647-0-01	J-23		145465-0-01	B-9-6		146089-0-01	J-11	
114931-0-01	A-9		140668-0-01	R-8		145467-0-01	B-11		146092-0-01	J-19	
114966-0-01	E-33-7		140678-0-00	Q-1-5-5		145472-0-01	E-4		146093-0-01	J-17	
114967-0-01	E-33-5		140682-0-01	Q-1-18-1		145473-0-01	E-19		146095-0-00	J-5	
115018-0-01	Q-9		140704-0-01	A-21		145476-0-01	E-28		146096-0-00	J-5-3	
115244-0-01	B-34		140726-0-00	B-30		145478-0-01	E-27		146097-0-00	J-5-2	
115663-0-01	C-48		140885-0-02	A-6		145479-0-01	E-30		146098-0-00	J-5-1	
116016-0-01	Z-31		140947-0-01	R-12-1		145480-0-01	E-29		146118-0-00	Q-1-24-4	
116112-0-01	A-32		140948-0-01	Q-2-1		145481-0-01	E-31		146119-0-00	H-19	
116766-0-01	C-51		140950-0-00	Q-2-4		145492-0-01	C-9		146120-0-01	J-26	
	C-62		140953-0-01	R-12-12		145502-0-01	C-16		146121-0-00	J-29	
116768-0-01	C-67		141207-0-01	E-11			D-60		146124-0-01	J-33	
116780-0-01	B-54		141208-0-01	E-9		145510-0-00	C-54		146125-0-01	J-31	
116794-0-01	F-14		141331-0-01	D-63		145516-0-01	B-40		146126-0-01	J-34	
116917-0-01	C-46			D-74		145517-0-01	B-63		146127-0-01	J-34-1	
116919-0-01	C-60		141542-0-01	H-32		145519-0-01	A-28-4		146128-0-00	J-34-2	
116920-0-01	C-53			Z-26		145520-0-01	A-28-8		146148-0-01	G-4	
	C-64		141728-0-01	E-8		145522-0-01	A-26		146149-0-01	G-11	
117132-0-01	B-57		142037-0-00	Q-1-18-7		145524-0-01	A-34		146153-0-01	G-14	
	Z-8		142038-0-01	Q-1-18-8		145526-0-01	E-21		146156-0-01	G-2	
117242-0-01	B-7		142268-0-01	J-24		145529-0-00	F-8		146157-0-01	R-3	
117243-0-01	B-5		142274-0-01	A-36		145534-0-01	F-13		146159-0-01	R-4	
117936-0-01	A-25		142349-0-00	Q-1-5-2		145543-0-01	F-23		146160-0-01	Q-2	
117963-0-01	Z-11		142443-0-01	Z-2		145573-0-00	E-32		146171-0-00	Q-1-3	
117969-0-01	Z-11-16		142573-0-01	C-57		145580-0-01	E-24		146175-0-01	R-12	
117970-0-01	Z-11-5		142628-0-01	D-7		145595-0-01	H-17		146178-0-01	R-12-13	
118672-0-01	A-20		142708-0-00	B-38		145596-0-01	Q-1-24-3		146196-0-01	F-37	
118729-0-01	C-37-3		142709-0-00	B-42		145608-0-01	H-31		146206-0-01	A-42	
118732-0-01	C-37-6		142746-0-01	D-69-2			Z-25		146253-0-00	F-30	
118733-0-01	C-37-7		142746-0-02	C-17-5		145610-1-01	H-29		146288-0-01	D-85	
118734-0-01	C-41			D-61-5		145611-0-00	H-30			J-20	
118735-0-01	C-43			D-69-14		145617-0-01	H-44		146293-0-01	F-40-9	
118736-0-01	C-40		142747-0-01	D-69-1		145621-0-01	H-45		146314-0-00	F-7	
118737-0-01	C-37-2		142747-0-02	C-17-6		145643-0-01	C-14		146324-0-01	F-32	
118740-0-01	C-38			D-61-6		145681-0-00	H-20		146327-0-01	B-17	
118748-0-01	C-28			D-69-13		145688-0-00	B-14		146333-0-01	B-16	
118753-0-01	C-14		143488-0-01	Q-2-6		145691-0-01	E-21		146358-0-01	R-12-15	
118758-0-01	C-2		143489-0-01	Q-2-5		145737-0-01	F-24		146367-0-01	F-40-13	
118759-0-01	B-41		143549-0-00	H-14-5-3		145751-0-01	B-62		146912-0-00	J-5	
118761-0-00	B-51			J-5-4		145944-0-01	B-2		146913-0-00	J-29	
118762-0-00	B-49			J-29-2		145945-0-01	Z-23		146985-0-01	F-40-7	
118768-0-01	F-27			Q-1-24-2		145946-0-01	Z-22		146986-0-01	R-7	
118824-0-01	C-30			Q-2-3		145990-0-01	Z-24		147060-0-01	Z-34-8	
118837-0-01	Z-3		143882-0-01	Z-15		146003-1-01	Z-18		147141-0-01	R-2	

Parts No.	Ref. No.	Remark	Parts No.	Ref. No.	Remark	Parts No.	Ref. No.	Remark	Parts No.	Ref. No.	Remark
147197-0-01	E-26		150173-0-01	Z-34-6-1		151361-0-01	D-40-4		151602-0-02	A-8	
147551-0-01	B-9		150177-0-01	Z-34-13		151362-0-01	D-17-4			H-14-22	
147697-0-01	H-27		150179-0-01	Z-34-7		151363-0-01	D-17-1		151603-0-01	D-67	
147705-0-01	A-41		150180-0-00	Z-34-10		151364-0-01	D-51-3		151603-0-02	B-52	
147777-0-00	B-9-4		150181-0-01	Z-34-16-2		151366-0-01	D-12		151604-0-01	B-23	
147846-0-01	E-10		150182-0-00	Z-34-9		151367-0-00	D-19			B-29	
147855-0-01	Z-28-8		150189-0-01	Z-34-16-1		151368-0-00	D-14			C-1-2	
147856-0-01	Z-28-7		150192-0-01	Z-34-4		151369-0-01	D-10			C-4-2	
147893-0-01	Z-30		150202-0-01	Z-34-6-2		151370-0-01	D-46			C-8	
147895-0-11	Z-28		150352-0-00	H-14-25		151372-0-01	D-47			C-30-1	
148286-0-01	C-58		150375-0-01	H-14		151373-0-01	D-51			C-42	
148350-1-01	B-60		150551-0-00	A-30		151375-0-00	D-51-5			D-8	
148823-0-01	B-34		151256-0-01	A-14		151376-0-01	D-51-4			D-13	
148825-0-01	K-6		151257-0-01	A-14		151377-0-01	D-53			D-26	
148848-0-01	F-36-5		151258-0-01	A-10		151382-0-01	D-53-4			D-38-2	
148849-0-01	F-36-6		151260-0-01	B-25		151383-0-01	D-54			D-39-2	
148853-0-01	G-5		151261-0-01	B-65		151384-0-01	D-54		151605-0-02	B-15	
148965-0-00	B-20		151262-0-01	B-65		151390-0-01	D-44		151606-0-01	B-21	
148967-1-01	B-59		151267-0-01	B-66		151391-0-01	D-45			B-31-2	
149087-0-01	G-20		151268-0-01	E-5		151392-0-01	D-43			B-37-2	
149094-0-01	G-19		151269-0-01	E-13		151393-0-01	D-48			B-37-4	
149095-0-01	G-17		151272-0-01	E-23		151395-0-01	D-3			B-44-2	
149104-0-01	H-47		151274-0-01	E-17		151396-0-01	D-5			B-44-3	
149105-0-00	H-46		151275-0-01	E-15		151397-0-01	D-2			C-70	
149106-0-01	H-48		151276-0-01	E-14		151398-0-01	D-6			D-27-2	
149108-0-01	H-14-5		151277-0-01	E-1		151399-0-00	D-9			D-36-2	
149112-0-01	H-14-14		151281-0-01	E-1		151400-0-01	D-40		151607-0-01	B-50	
149113-0-01	H-14-12		151301-0-01	C-5		151401-0-01	D-40-1		151626-0-01	D-51-2	
149114-0-01	H-14-11		151303-0-01	C-37		151403-0-01	D-30		152187-0-01	H-14	
149115-0-01	H-14-17		151304-0-01	C-10		151405-0-01	D-76		152188-0-01	H-14-5	
149118-0-01	H-14-20			C-37-1		151406-0-01	D-78		153060-0-01	D-17-3	
149119-0-01	H-14-21		151305-0-01	C-37-9		151407-0-01	D-68		153110-0-01	D-51-7	
149120-0-01	H-14-6		151306-0-01	C-32		151409-0-01	D-72		153113-0-01	D-49	
149121-0-01	H-14-8		151308-0-01	C-11		151412-0-01	D-69		153131-0-01	B-54	
149123-0-01	H-42			C-33		151413-0-01	D-69-9		153132-0-00	A-49	
149124-0-01	H-37		151309-0-01	C-34		151414-0-01	D-69-5		153169-0-01	D-86	
149125-0-01	H-41		151310-0-01	C-36		151415-0-01	D-69-10		180018-0-01	B-64	
149127-0-01	H-12		151311-0-01	C-7		151416-0-01	D-69-15		180321-0-01	C-69	
	H-38		151312-0-01	C-25		151417-0-01	D-69-3			D-27	
149128-0-01	H-25		151313-0-01	G-23		151418-0-01	D-82			D-36	
149130-1-01	H-7		151314-0-00	C-27		151419-0-00	F-2		180791-0-01	C-1	
149131-0-01	H-13		151315-0-01	C-18		151420-0-00	F-5		180792-0-01	C-4	
149132-0-01	H-8		151316-0-01	G-22		151421-0-00	F-6		180952-0-01	E-6	
149133-1-01	H-5		151317-0-01	C-19		151422-0-00	F-6		181420-2-01	F-40	
149136-0-01	H-4		151318-0-01	C-23		151424-0-01	D-23		181427-0-01	E-33	
149137-0-01	H-3		151319-0-01	G-21		151425-0-00	F-29		181430-2-01	F-40	
149247-0-01	Z-29		151320-0-01	C-17-3		151426-0-01	F-31		181476-1-01	F-36	
149539-0-01	Q-1			D-61-3		151428-0-00	F-33		181634-0-01	A-28	
149543-0-01	Q-1-18			D-69-4		151429-0-01	F-26		181916-0-01	B-31	
149544-0-01	Q-1-18-3		151321-0-01	C-17-4		151430-0-01	A-3		181937-0-01	B-60-1	
149545-0-01	Q-1-24		151322-0-01	C-47		151431-0-01	A-2		181938-0-01	B-60-2	
149547-0-00	Q-1-12		151324-0-01	C-50		151432-0-01	H-1		181995-0-01	B-48	
149578-0-00	F-40-6		151325-0-01	C-50		151433-0-01	A-3		182392-0-01	B-60-3	
149580-0-01	F-40-4		151330-0-01	C-66		151434-0-01	J-13		183005-0-01	D-38	
149581-0-01	F-40-4		151332-0-01	C-12		151435-0-01	J-15		183006-0-01	D-39	
149709-0-01	H-28		151333-0-01	G-7		151436-0-00	J-22		200084-0-02	T-6-5	
149710-0-01	H-33		151334-0-01	G-9		151437-0-01	K-4		206156-0-01	T-6-36	
149712-0-01	H-34		151343-0-01	G-16		151438-0-01	K-3		206337-0-02	T-6-93	
149722-0-01	H-14-18		151345-0-01	G-12		151439-0-01	E-18		206755-0-00	Q-1-23	
149723-0-01	H-14-19		151346-0-01	D-61-4		151443-0-01	C-17		210240-0-01	T-6-77	
149724-0-01	H-14-26		151347-0-00	D-58		151444-0-01	C-65		210421-0-00	T-6-51-6	
149725-0-01	H-21		151348-0-01	D-34		151445-0-01	D-61		210938-0-01	T-6-32	
149726-0-01	H-39		151350-0-01	D-35		151448-0-01	F-4		210940-0-00	T-6-31	
149775-0-01	H-11		151351-0-01	D-33		151601-0-02	B-53-1		210941-0-02	T-6-41	
149998-0-00	F-34		151352-0-01	D-29			C-6			T-6-51-2	
149999-0-00	F-35		151353-0-01	D-83			C-31		210942-0-02	T-6-42	
150106-0-01	Z-34-6		151354-0-01	D-24			C-37-4			T-6-51-1	
150139-0-01	Z-34-16		151359-0-01	D-25			C-39		210948-0-01	T-6-51-5	
150150-0-01	Z-34		151360-0-01	D-17			C-44		210965-0-01	T-6-24	
150172-0-01	Z-34-5		151361-0-01	D-17-5			D-4		210973-0-01	T-1	

Parts No.	Ref. No.	Remark	Parts No.	Ref. No.	Remark	Parts No.	Ref. No.	Remark	Parts No.	Ref. No.	Remark
211528-0-01	T- 6- 3		218819-0-01	S- 1- 3		219486-0-00	T- 6-44-13				
	T- 6-44-15		218821-0-01	S- 1-21		219487-0-00	T- 6-44-13				
	T- 6-78		218823-0-01	S- 1- 5		219488-0-00	T- 6-44-13				
	T-10		218831-0-01	T- 6-20		219497-0-01	T- 6				
212251-0-01	R-12- 2		218860-0-01	T- 6-63		219499-0-01	T- 6-44				
212544-0-01	T- 6-98-25		218861-0-01	T- 6-15		219501-0-00	S- 1- 4				
213646-0-01	T- 5		218861-0-02	T- 6-17		219505-0-00	S- 1- 4				
213650-0-01	T- 2		218861-0-03	T- 6-18		219507-0-01	T- 6				
213748-0-01	T- 6- 7		218862-0-01	T- 6- 8		219509-0-01	T- 6-44				
213750-0-00	T- 6-51-3		218863-0-01	T- 6- 1		219698-0-01	S- 1-19				
213752-0-01	T- 6-25		218864-0-01	T- 6-49		219699-0-01	S- 1-20				
213757-0-02	T- 6-80		218865-0-01	T- 6- 4		219726-0-01	T- 6				
213760-0-01	T- 6-94		218866-0-01	T- 6-47		219728-0-00	T- 6-34				
213765-0-01	T- 6-23		218867-0-01	T- 6-48		219729-0-01	T- 6-39				
213792-0-01	T- 6-16		218870-0-01	T- 6-44-2		219730-0-01	T- 6-44				
213794-0-01	S- 1-12		218871-0-01	T- 6-37		219731-0-00	T- 6-44-13				
213802-0-01	T- 6-35		218872-0-01	T- 6-39		219733-0-01	T- 6				
213913-0-01	T- 6-98-10		218873-0-00	T- 6-40		219734-0-00	T- 6-34				
214002-0-01	T- 6-98-19		218874-0-01	T- 6-21		219735-0-01	T- 6-44				
214344-0-01	S- 2		218875-0-01	T- 6-22		219736-0-00	T- 6-44-13				
214897-0-01	T- 6-43		218876-0-01	T- 6-72		219744-0-00	S- 1- 4				
215080-0-01	K- 2-10		218877-0-01	T- 6-51		219745-0-01	S- 1-11				
	K- 2-16		218878-0-00	T- 6-51-7		219746-0-01	S- 1- 9				
	S- 1- 2		218879-0-01	T- 6-51-8		219749-0-00	S- 1- 4				
	S- 1-10		218881-0-01	T- 6-74		219752-0-01	S- 1-20				
	T- 6-44-6		218882-0-00	T- 6-52		219791-0-01	T- 6				
	T- 6-58		218884-0-00	T- 6-85		219792-0-00	T- 6-34				
	T- 6-98-11		218885-0-01	T- 6-82		219934-0-01	T- 6				
215083-0-01	K- 2- 2		218891-0-01	T- 6-83		219935-0-00	T- 6-34				
215387-0-01	S- 1-25		218892-0-01	T- 6-84		219967-0-01	T- 6				
215491-0-01	T- 8		218893-0-01	T- 6-67		219968-0-00	T- 6-34				
215822-0-00	S- 1-24		218894-0-01	T- 6-66		219972-0-01	T- 6				
216219-0-00	T- 6-54		218895-0-01	T- 6-64		219973-0-01	T- 6-44				
216225-0-01	T- 6-98-1		218896-0-00	T- 6-62		219984-0-01	T- 6				
216230-0-01	T- 6-98-22		218902-0-01	T- 6-59		219985-0-00	T- 6-34				
216232-0-01	T- 6-98-17		218903-0-01	T- 6-88		219986-0-01	T- 6-44				
216233-0-01	T- 6-98-4		218905-0-01	T- 6-27		219987-0-00	T- 6-44-13				
216235-0-00	T- 6-98-6		218907-0-01	T- 6-44-4		220001-0-00	S- 1- 4				
216236-0-01	T- 6-98-24		218910-0-00	T- 6-44-5		220010-0-01	S- 1-11				
216241-0-01	T- 6-98-8		218911-0-01	T- 6-44-10		220070-0-01	S- 1-19				
216247-0-01	T- 6-92		218912-0-00	T- 6-44-16		220965-0-01	S- 1				
216248-0-01	T- 6-91		218913-0-01	T- 6-44-1		220966-0-01	S- 1				
216277-0-01	T- 6-87		218915-0-01	T- 6-69		220967-0-01	S- 1				
216284-0-00	T- 6-44-14		218916-0-01	T- 6-44-18		220968-0-01	S- 1				
216286-0-01	T- 6-44-9		218918-0-01	T- 6-44-21		220969-0-01	S- 1				
216299-0-01	T- 6-44-7		218919-0-01	T- 6-44-22		220970-0-01	S- 1				
216300-0-01	T- 6-44-8		218920-0-00	T- 6-44-23		220971-0-01	S- 1				
216345-0-00	S- 1-14		218921-0-01	T- 6-44-19		220972-0-01	S- 1				
216346-0-01	S- 3			T- 6-98-2		220974-0-01	S- 1				
216351-0-00	S- 1-15		218922-0-01	T- 6-44-17		220975-0-01	S- 1				
216364-0-00	S- 1-22		218923-0-01	T- 6-98		220976-0-01	S- 1				
216373-0-01	S- 1- 1		218924-0-01	T- 6-98-3		220977-0-01	S- 1				
216380-0-01	T- 6-79		218925-0-01	T- 6-98-20		221051-0-01	S- 1				
216837-0-01	T- 6-90		218926-0-01	T- 6-98-16		290439-0-00	T- 6-53				
216870-0-01	S- 1- 7		218927-0-01	T- 6-98-21							
216880-0-01	K- 2-13		218928-0-01	T- 6-96		151449-0-01	D-73-75				
216905-0-01	S- 1-23		218929-0-01	T- 6-95		151450-0-01	D-62-64				
216921-0-01	T- 7		218930-0-01	T- 6-71							
216922-0-01	T- 7		218931-0-01	K- 2							
216923-0-01	T- 7		218945-0-01	T- 6-98-5							
216924-0-01	T- 7		218946-0-01	T- 6-98-7							
216925-0-01	T- 7		218947-0-01	T- 6-98-23							
217093-0-01	K- 2- 7		218951-0-01	T- 6-14							
217135-0-01	T- 7		218952-0-01	T- 6-81							
217136-0-01	T- 7		218953-0-01	K- 2- 8							
217169-0-00	T- 6-50		219235-0-01	T- 6-44-4							
217249-0-00	S- 1-22		219405-0-01	T- 6-75							
217280-0-01	T- 6-44-20		219483-0-00	T- 6-34							
	T- 6-65		219484-0-00	T- 6-34							
217805-0-01	T- 6-35		219485-0-01	T- 6-34							

